



www.tzhldz.cn

Hanglong Electronics

HANG LONG ELECTRONIC

Product Selection Guide
Professional / Reliable / Innovative

Taizhou Hanglong Electronics Co.Ltd.

TAIZHOU HANGLONG ELECTRONIC CO.,LTD.



» Company Profile

Taizhou Hanglong Electronics Co., Ltd., headquartered in Dasheng Industrial Park, Jichuan Subdistrict, Taixing City, was established in 2008 and rebranded as a limited company in September 2015 with a registered capital of 5 million yuan. The company specializes in manufacturing and selling electrical connectors, electronic components, switch connectors, stamped parts, industrial automation equipment, and metal products, along with retailing cables and feeder lines.

As a professional manufacturer of electrical connectors, the company integrates R&D, production, sales, and service. Its main product lines include the Y50 series, YGD series, XC series, YMG series, and 1599 series. These products are widely used in strategic and tactical systems such as aerospace, aviation, assembly, military command, rocket forces, weaponry, marine equipment, and railways, as well as in electronic countermeasures, field power supply, communication signal systems, and industries like new energy vehicles, medical equipment, coal mining, and industrial transmission. Our company's products feature three-proof functions, high density, high reliability, and electromagnetic compatibility. We can also develop and produce various special electrical connectors for different users to meet their needs. The high-tech products are as follows :

1、 photoelectric hybrid connector

Our company's independently developed photoelectric hybrid round connector complies with GJB599B (MIL-DTL-38999K) Series III standards. Featuring a three-thread quick-connect mechanism with anti-loosening features, it offers compact size, high contact density, electromagnetic shielding, detachable crimped contacts, and anti-sloping pin insertion. The stainless steel housing ensures high salt spray resistance, making it ideal for humid and harsh environments with enhanced operational stability.

2、 New Energy Series of Series Connectors

In response to the growing demand for sustainable urban development, new energy vehicles (NEVs) have seen widespread adoption in recent years. Our company has developed specialized crimp-type circular electrical connectors specifically engineered for NEVs, meeting GJB2889 standards. These connectors feature a snap-fit quick-connect/disconnect mechanism that ensures easy operation, secure connections, and robust vibration resistance. The high-strength aluminum alloy housing incorporates a rear-release crimping design with double-curved spring sockets, delivering smooth insertion/removal, low contact resistance, and protection against moisture, salt fog, mold, and rain. The innovative sealing ring design with a compression-type tail section enhances waterproof performance, achieving IP67 protection. The spring socket technology effectively prevents signal instability caused by vehicle vibrations, significantly improving safety and reliability. These innovations have gained recognition from major domestic NEV manufacturers and are now widely adopted in the industry.

Our company has always upheld the corporate ethos of 'Integrity as the foundation, unity and hard work for practical innovation, and the pursuit of excellence,' adhering to

Our quality policy, "Customer-focused, customer-oriented, technology-driven, and service-integrity," is embodied in premium products, exceptional service, and competitive pricing—all dedicated to serving our customers wholeheartedly.

Taizhou Hanglong Electronics Co., Ltd. cordially welcomes domestic and international clients to collaborate and discuss business opportunities!

MIL-DTL-38999 Series I Connectors

This series of round electrical connectors complies with GJB599A (MIL-DTL-38999K) I-series standards, featuring snap-fit quick connections. Designed for compact size, lightweight construction, high contact density, EMI/RFI shielding, and anti-sloping insertion, the connectors offer both crimped and welded contact types. Crimped connectors support detachable crimping, while sockets are available in box-type, wall-type, front-mounted, rear-mounted, and nut-tightening configurations. The product demonstrates high-strength vibration resistance and meets GJB1784A tail accessory standards, specifically designed for shielding cable clamping with Ti-Ni alloy memory rings. Available in nine housing sizes, it features sealed mating surfaces and tail interfaces with excellent three-proof performance (IP65 rating). The five-key guide mechanism includes five anti-misalignment key positions, making it widely applicable in aerospace, defense, and other military systems as well as electronic equipment applications.

Product Logo Code

$\frac{HL}{1}$ $\frac{MS}{2}$ $\frac{27467}{3}$ $\frac{T}{4}$ $\frac{17}{5}$ $\frac{F}{6}$ $\frac{35}{7}$ $\frac{P}{8}$ $\frac{N}{9}$

1. Enterprise Name: Taizhou Hanglong Electronics Co.,Ltd.

2. Main Name Code of Circular Electrical Connector

3 Type 1: 27467-Plug (only Type T):

27466 Wall-mounted square tray with front-mounted socket (Class T only); 27656 Wall-mounted square tray with rear-mounted socket (Class T only); 27496 Box-type square tray with front-mounted socket (Class E only); 27505 Box-type square tray with rear-mounted socket (Class E only); 27468 Nut-type socket installation (Class T only)

4— Shell type: T-shaped with threaded tail for mounting accessories;

E-The tail end is without threads, and the rear attachment

5—shell numbers: 09,11,13,15,17,19,21,23,25 cannot be installed.

6— Shell coating: B-cadmium-plated military green; C-anodized; E-stainless steel passivation; F-nickel electroless plating; F-sandblasted nickel;

S-Nickel-chromated: C3-Zinc-nickel alloy black (black chrome): C1-Military green oxide: C2-Black oxide

7 Contact arrangement: See the "Contact arrangement" diagram for details

8 P-press-fit pin (500 insertion/withdrawal cycles) PH-welded pin PC-short printed circuit board pin PL-long printed circuit board pin

H-Pressed pin, 1500 insertion and removal cycles HH-Welded pin HC-Short printed circuit board pin HL-Long printed circuit board pin

S-crimped socket, withstand 500 insertion/withdrawal cycles SH-welded socket SC-short printed circuit board socket SL-long printed circuit board socket

J-crimping socket, 1500 insertion/withdrawal cycles H-soldering socket JC-short printed circuit board socket JL-long printed circuit board socket

CD-Externally a pin, internally a hole, with the flange located outside the compartment (wall-penetrating seat)

DC-Externally a hole, internally a needle, with the flange located outside the compartment (wall-penetrating seat)

9 N-normal bond positions A, B, C.D, E one variable bond position

Note: The Chinese military standard GJB599A and the U.S. military standard MIL-DTL-38999K share identical model designations except for their primary designations. GJB599A is designated as 'JY', while MIL-DTL-38999K is designated as 'MS'. Both standards are interchangeable.

Product Technical Characteristics

I. Environmental Conditions for Use

Operating temperature: Class B-65°C~+175°C

Class C.E and F-65°C to +200°C

Salt spray resistance: Test performed according to GJB1217 Method 1001.

Class B: 500 h; Class C: 96 h;

Class F: 48 h; Class D: 1000 h

Relative humidity: 98% at 40°C

Operating altitude: ≤30,480m. The electrical connector also exhibits excellent performance in moisture resistance, salt spray resistance, mold resistance, rain protection, and dustproofing.



MIL-DTL-38999 Series I Connectors

II. Electrical Characteristics

Contact resistance and rated current of contact

Contact specifications	Working diameter mm	Contact resistance mΩ	Rated current A
22D	①0.76	<12	5
20 “	φ 1.0D	<5	7.5
16#	①1.60	<2.5	13
12#	①2.40	≤1.5	23
10#	①3.15	<1.0	40

Electromagnetic interference shielding:

The minimum attenuation is 85dB at frequencies ranging from 100MHz to 1 GHz.

The minimum attenuation is 50dB in the frequency range of 1GHz to 10GHz.

withstand voltage (V)

Job level	M	N	I	II
Sea level	1300	1000	1800	2300
21000m	B00	B00	1000	1000

◆ Different contact arrangements have different working levels. See contact arrangement for details.

insulation resistance :

Normal conditions >5000MQ; Humid conditions >100MQ

Electrical continuity between the outer shells:

Category B: ≤2.5 mQ; Category F: ≤1.0 mΩ; Category E: <5 mΩ

III. Mechanical Properties

Shell: Aluminum alloy, Stainless steel

Coating: Type B (cadmium-plated military green) and Type C (anodized)

Class E Stainless steel passivation Class F Chemical nickel plating

Insulator: Thermosetting plastic

Sealing Body and Sealing Ring: Silicone Rubber Material

Contact type: gold-plated copper alloy, crimped type, soldered type, printed circuit board type

Mechanical lifespan: ≥500 insertions and extractions

Vibration: Sine vibration, frequency 10~2000 Hz, acceleration 294 m/s²

Random vibration: frequency 100~1000Hz, power spectral density 1G^{1/3}/H; impact: 3ms half-sinusoidal wave, peak acceleration 300g

IV. Marking of Pressed Contact Parts

Contact specifications	Diameter mm	Pin Color Label	Plug color code	Inner diameter of the wire roll mm	Outer diameter of wire roll mm	Adaptation Lead Section mm ³	Adapt to US standard cable AWG	Insulated outer diameter of adapter wire mm	Tool code for removal
22D “	0.76	Orange, blue, and black	Orange, Yellow, and Brown	0.85	1.20	0.08B 0.125 0.2 0.3	2B 26 24 22	0.76~1.37	M81969/ 14-01
20#	1.00	Orange, blue, and orange	One green, one brown	1.17	1.7B	0.2 0.3 0.5	24 22 20	1.02~2.11	M81989/ 14-10
16#	1.60	Orange, blue, and yellow	Orange, green, and red	1.6B	2.62	0.5 0.8 1.0 1.2	20 18 16	1.65~2.77	MB1968/ 14-03
12”	2.40	Orange, blue, and green	Orange, green, and orange	2.48	3.84	2.0 3.0	14 12	2.46~3.61	M81989/ 14-04
10#	3.15	Green, red, and gray	Green, orange, purple	3.40	4.65	3.0 4. sun	12 10	3.42~4.12	M81969/ 14-05

Note: The required crimping tools and their usage instructions are provided in Appendix 1 (Page P 103).

MIL-DTL-38999 Series I Connectors

5. Contact Arrangement (View of Needle Insulator Insertion Surface)



0B-35 M



09-98 I

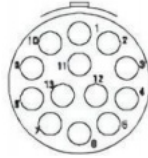

11-35 M

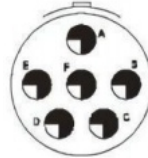

11-98 I

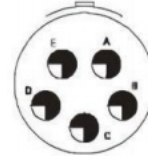

11-051

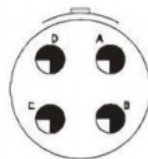

11-04 I



11-01 I

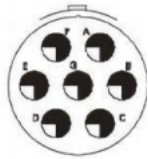

11-89 I

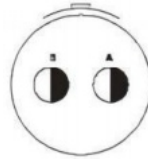

11-021

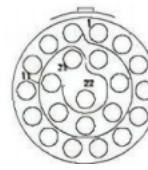

13-35 M



13-981

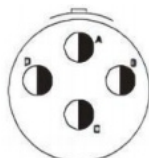

13-D4 I

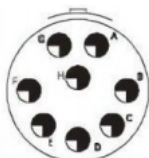

13-0B 1



13-03II

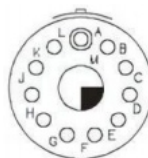

13-12

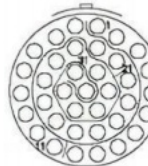

15-35 M

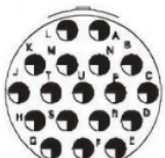

15-1B 1

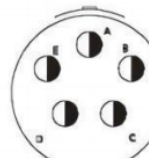

15-05 Mouth

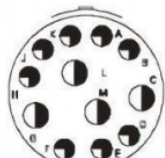

15-971

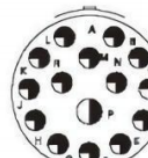

15-15 I



15-191



15-03 II

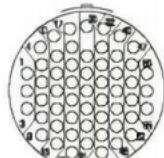

17-35 M

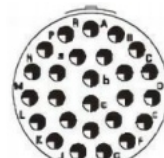

17-26 I

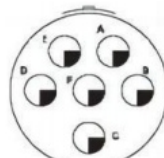

17-06 I

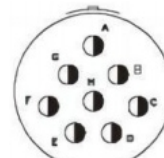

17-0B port

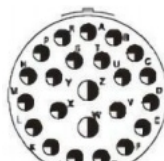

17-89 I

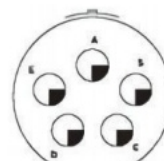

17-05II

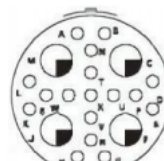

17-21

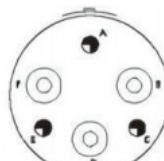

17-30 N

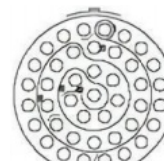

17-42 M

MIL-DTL-38999 Series I Connectors

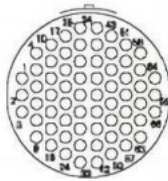

19-321

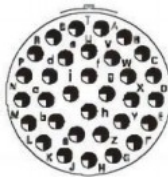

19-28 I

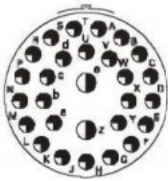

19-11 II

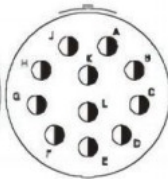

19-93

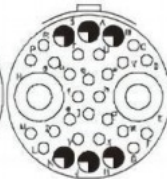

19-30 J

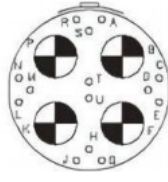

19-18

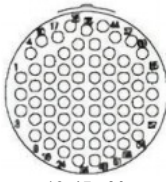

19-45 M

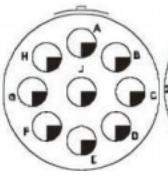

18-9B K

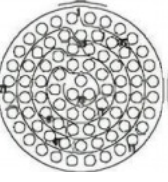

21-35 M



21-41 I

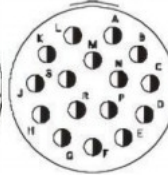

21-18II

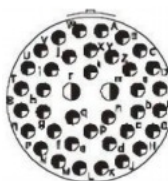

21-39 I

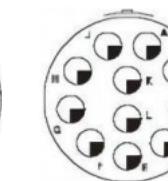

21-11 Mouth

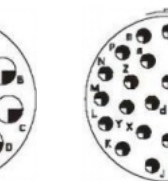

21-27 I

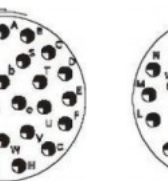

21-25 I

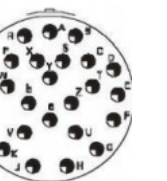

21-24 I

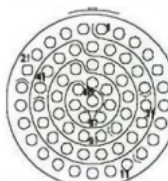

21-02 M

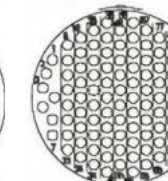

23-35 M

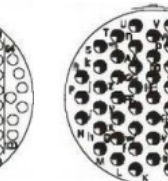

23-55 K

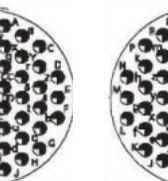

23-53 I

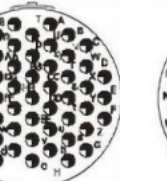

23-36 I

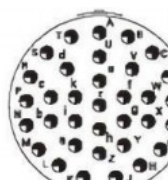

23-341

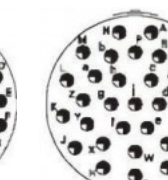

23-321

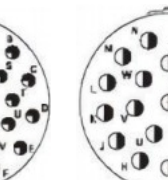

23-21III

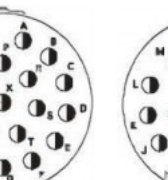

23-97 I

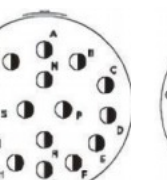

23-99 II

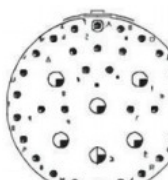

23-37

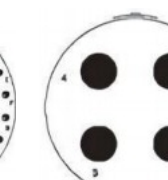

23-04 I

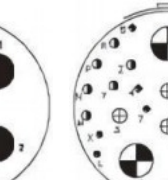

25-20

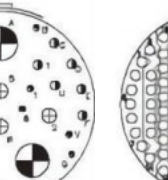

25-35 M

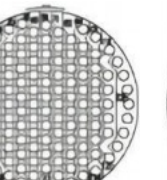

25-02 M



25-29 I

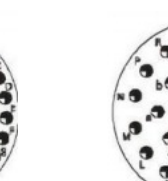

25-24 K



25-431



MIL-DTL-38999 Series I Connectors

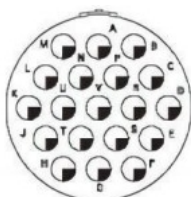

25-10 I

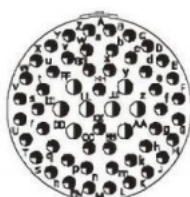

25-04 I

Note: The diameter of the contact parts is marked as 022D# 20#016# 12#©10# 8# 8# Double coaxial

VI. Preventing Incorrect Insertion of Healthy Positions

socket key angle

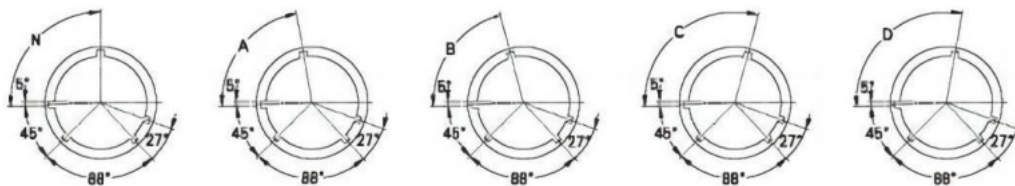

Plug Key Angle

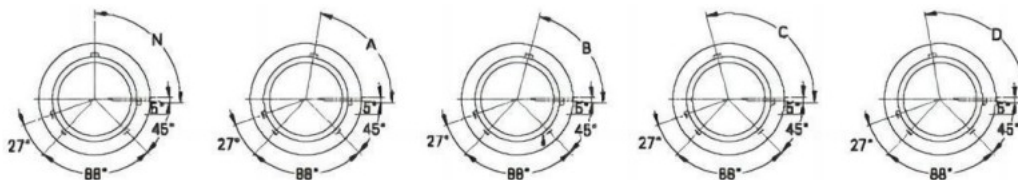

Key code	08	11	13	15	17	19	21	23	25
N	95°	95°	95°	96°	96°	95°	95°	96°	96°
A	77°	81	75°	74°	77°	77°	77°	80°	80°
B		67°	63°	61*	65°	65°	65°	69*	69*
C	--	123°	127°	129°	125°	125°	125°	121*	121
D	113°	109°	115°	116°	113°	113°	113°	110°	110°

MIL-DTL-38999 Series I Connectors

VII. Dimensions

1、 Plug JY27467

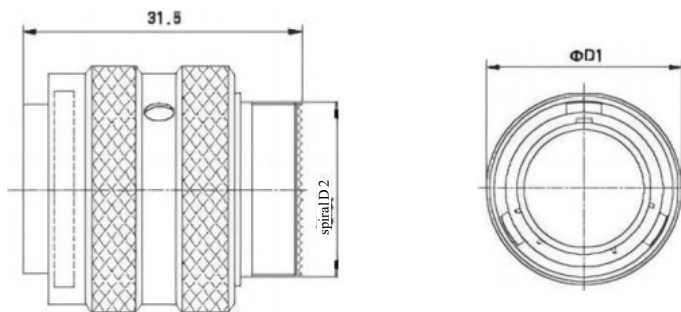

Luminous Body	D1	Thread D2 UNF-2A
09	21.7	0.4375-28
11	25.0	0.5625-24
13	28.2	0.6875-24
15	31.3	0.8125-20
17	34.4	0.9375-20
19	37.4	1.0625-18
21	40.5	1.1875-18
23	44.0	1.3125-18
25	46.8	1.4375-18

2、 Nut Installation Socket JY27468

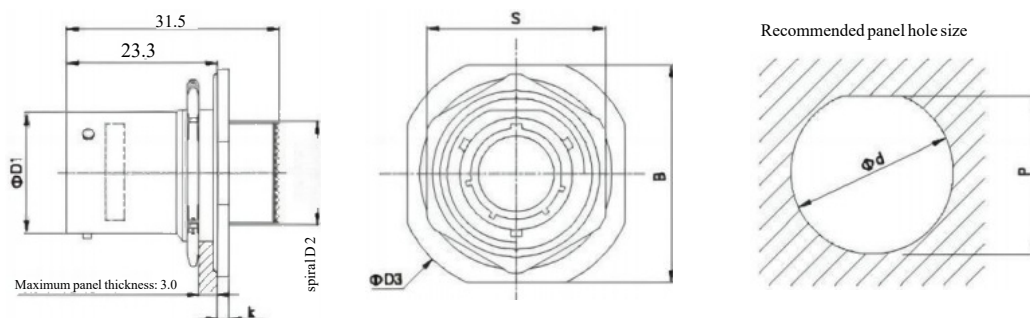

Shell number	D1	Thread D2 UNEF-2A	D3	K	B	S	d	P
09	14.5	0.4375-28	30.2	2.4	27.0	22.3	17.7	17.0
11	17.8	0.5625-24	35.0	2.4	31.8	25.5	21.0	19.6
13	21.6	0.6875-24	38.1	2.8	35.0	30.2	25.6	24.3
15	24.8	0.8125-20	41.3	2.8	38.1	33.4	28.8	27.3
17	27.9	0.9375-20	44.5	2.8	41.3	36.6	32.0	30.7
19	30.7	1.0625-18	49.3	3.6	46.0	39.7	35.2	33.8
21	33.8	1.1875-18	52.4	3.6	49.2	42.9	38.3	37.1
23	37.0	1.3125-18	55.6	3.6	52.4	46.1	41.5	40.0
25	40.1	1.4375-18	58.8	3.6	55.6	50. sun	44.7	43.4

MIL-DTL-38999 Series I Connectors

3、Wall-mounted square socket JY27466 JY27656

Wall-mounted square tray with pre-installed socket (JY27466)

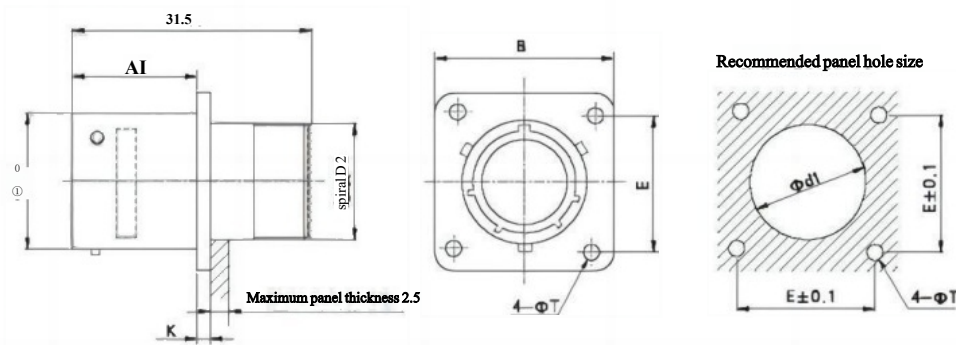

Wall-mounted square plate with rear-mounted socket (JY27656)

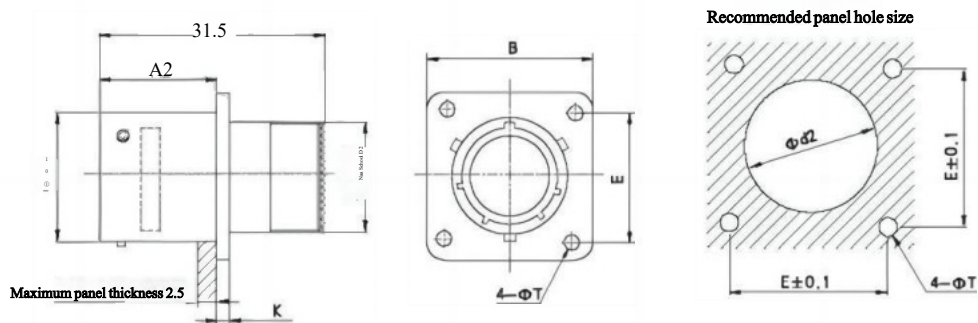

Complete Body Number	D1	Thread D2 UNE-2A	A1	A2	K	Sun	E	T	d1	d2
09	14.6	0.4375-28	16.1	20.9	2.4	23.8	18.26	3.2	12.5	16.7
11	17.8	0.5625-24	16.1	20.9	2.4	26.2	20.62	3.2	15.5	20.2
13	21.6	0.6875-24	16.1	20.9	2.4	28.6	23.02	3.2	19.5	24.5
15	24. sun	0.8125-20	16.1	20.9	2.4	31.0	24.62	3.2	21.5	27.7
17	28.0	0.9375-20	16.1	20.9	2.4	33.3	26.98	3.2	25.0	30.9
19	30.7	1.0625-18	16.1	20.9	2.4	36.5	29.36	3.2	28.0	32.9
21	33.8	1.1875-18	15.3	20.1	3.1	39.7	31.76	3.2	31.5	36.2
23	37.0	1.3125-18	15.3	20.1	3.1	42.9	34.92	3.7	34.5	39.3
25	40.2	1.4375-18	15.3	20.1	3.1	46.0	38.10	3.7	37.5	42.5

MIL-DTL-38999 Series I Connectors

4、 Box-Type Square Socket JY27496 JY27505 Pre-installed socket for box-type square tray (JY27496)

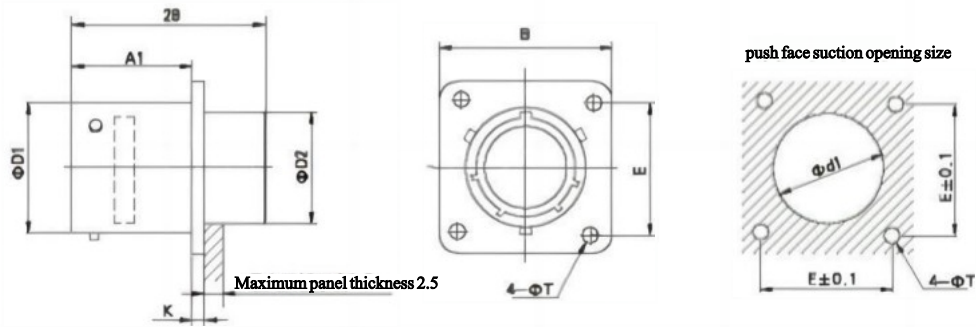

Box-type square plate with rear-mounted socket (JY27505)

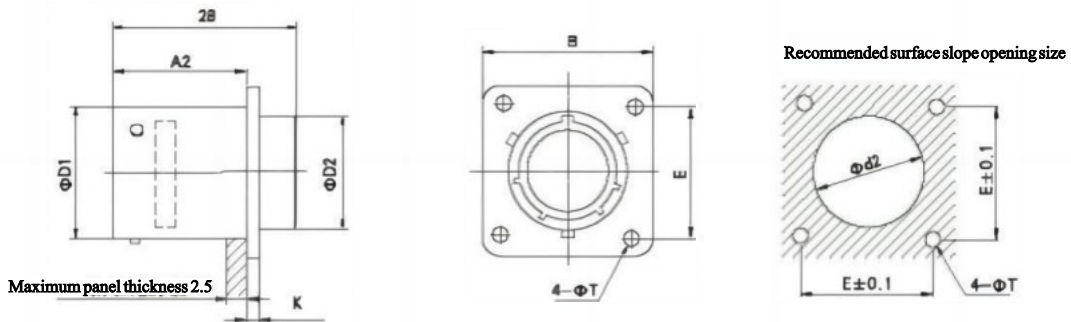

Shell number	D1	D2	A1	A2	K	S_{min}	E	T	d1	d2
0B	14.6	11.2	16.1	20.9	2.4	23.8	18.26	3.2	12.5	16.7
11	17.8	14.5	16.1	20.9	2.4	26.2	20.82	3.2	15.5	20.2
13	21.6	18.0	16.1	20.9	2.4	28.6	23.02	3.2	19.5	24.5
15	24.8	20.5	16.1	20.8	2.4	31.0	24.82	3.2	21.5	27.7
17	28.0	23.8	16.1	20.9	2.4	33.3	26.98	3.2	25.0	30.9
19	30.7	26.5	16.1	20.9	2.4	36.5	29.36	3.2	28.0	32.8
21	33.8	29.7	15.3	20.1	3.1	39.7	31.76	3.2	31.5	36.2
23	37.0	32.8	15.3	20.1	3.1	42.8	34.82	3.7	34.5	38.3
25	40.2	36.0	15.3	20.1	3.1	46.0	38.10	3.7	37.5	42.5

MIL-DTL-38999 Series I Connectors

5、 Socket With Printed Circuit Board Contact

JY27468 socket

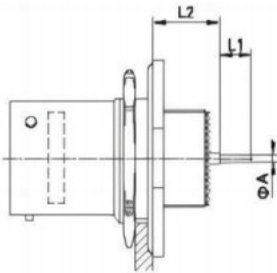

JY27466 socket

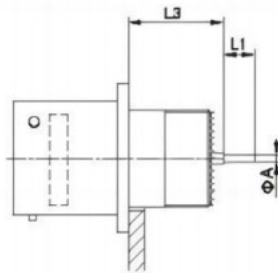

JY27656 socket

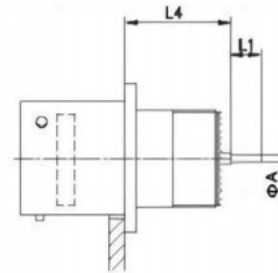

PCB contact specifications		L1	A
22D#	Long printed circuit board contact	8.5	0.7
	Short board contact	4.0	
20#	Long printed circuit board contact	8.5	0.7
	Short board contact	6.0	
16#	Long printed circuit board contact	8.5	1.15
	Short board contact	6.0	

Dimensions for installing contact pieces of different specifications			Case numbers: 09-11-13-15-17-19	Shell numbers 21-23-25
L2	When installing the 22# pin	Maximum	10.06	10.06
		Minimum	9.06	9.06
	When installing the 22# socket	Maximum	10.06	10.06
		Minimum	8.74	8.74
	When installing 20# or 16# pins and sockets	Maximum	10.23	10.23
		Minimum	8.24	9.24
L3	When installing the 22# pin	Maximum	15.08	15.08
		Minimum	13.91	13.91
	When installing the 22# socket	Maximum	15.08	15.08
		Minimum	13.58	13.58
	When installing 20# or 16# pins and sockets	Maximum	15.25	15.25
		Minimum	14.08	14.08
L4	When installing the 22# pin	Maximum	12.47	13.22
		Minimum	11.80	12.35
	When installing the 22# socket	Maximum	12.47	13.22
		Minimum	11.27	12.02
	When installing 20# or 16# pins and sockets	Maximum	12.64	13.39
		Minimum	11.77	12.52

MIL-DTL-38999 Series I Connectors

8. Rear Dimensions of Plug and Socket Assembly

Wall-mounted square socket (JY27656) / Plug (JY27467)

Wall-mounted square tray with pre-installed socket (JY27466) / plug (JY27467)

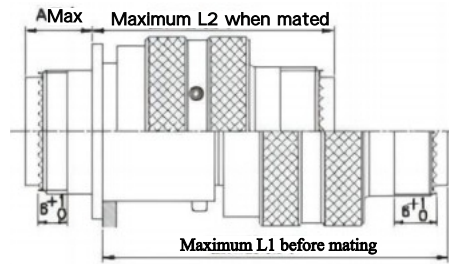
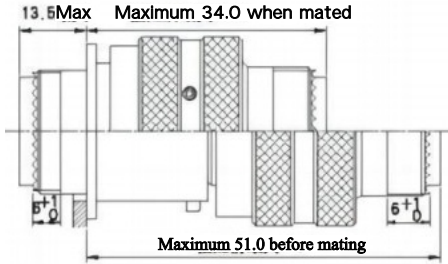

Front-mounted socket for box-type square tray (JY27496) / Plug (JY27467) Rear-mounted socket for box-type square tray (JY27505) / Plug (JY27467)

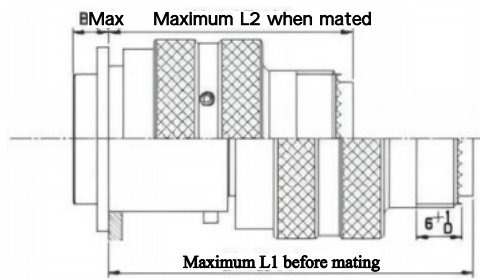
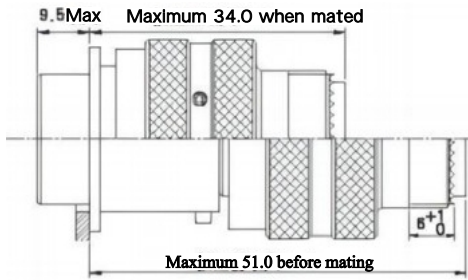

Nut installation socket (JY27468) / plug (JY27467)

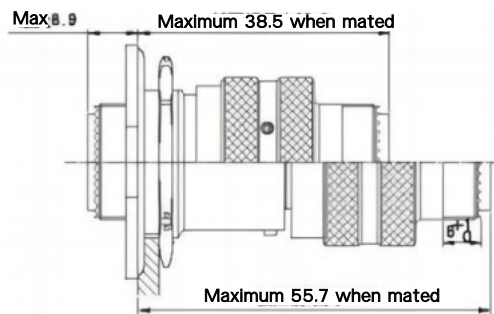

Shell number		09	11	13	15	17	19	21	23	25
L1	MAX	53.3	53.3	53.3	53.3	53.3	53.3	52.5	52.5	52.5
L2	MAX	36.4	36.4	36.4	36.4	36.4	36.4	35.6	35.6	35.6
A	MAX	11.1	11.1	11.1	11.1	11.1	11.1	11.9	11.9	11.9
B	MAX	7.1	7.1	7.1	7.1	7.1	7.1	7.9	7.9	7.9

MIL-DTL-38999 Series I Connectors

IX. Product Marking Code for Plug and Socket Sealing Covers

$\frac{HL}{1}$ $\frac{MS}{2}$ $\frac{27501}{3}$ $\frac{F}{4}$ $\frac{11}{5}$ $\frac{C}{6}$ $\frac{L}{7}$

- 1 1. Taizhou Hanglong Electronics Co., Ltd. Corporate Name
- 2 — Main designation code for round electrical connector
- 3 — Basic component numbers: JY27501-Plug seal cover (corresponding to US military standard component MS27501); JY27502-Socket seal cover (corresponding to US military standard component MS27502)
- 4 Surface coating: **B-cadmium plating military green F-chemical nickel plating E-stainless steel passivation**
- 5 — Shell body numbers: 09,11,13,15,17,19,21,23,25
- 6 -Chain type: **A-No chain N-Stainless steel twisted chain ring (for JY27468 socket)C-**
Stainless steel twisted chain **R-Brocade rope S-Stainless steel rope**
- 7-**Length Mark: No mark-Standard**
length L-Chain length 127mm

The M-chain length is 152.4mm (applicable only to JY27501)
The N-chain length is 177.8mm (applicable only to JY27501)

Note: 1. JY27502 denotes a composite material sealing cap without coating, indicated by a "-" in the model designation.

2、The Sealing Cap Must Be Ordered Separately and Is Not Included With the Connector.

outline dimension

Plug seal cover JY27501 (MS27501)

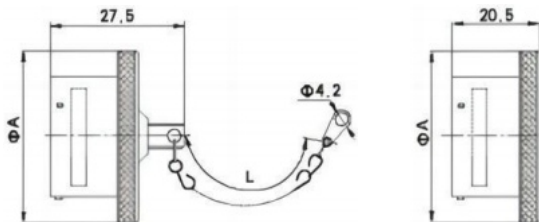

JY27502 (MS27502) socket sealing cap

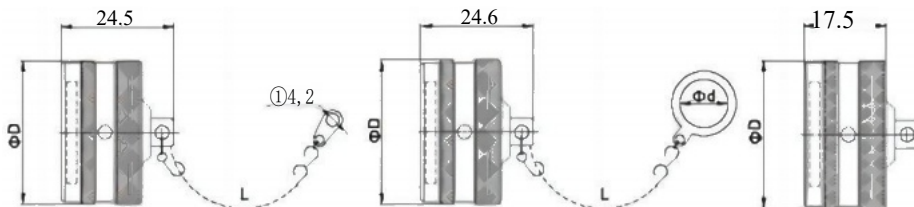

Shell number		09	11	13	15	17	19	21	23	25
A	MAX	20.5	23.7	26.9	30.1	33.2	36.4	39.6	42.8	45.9
D	MAX	21.7	23.5	29.0	31.6	34.8	38.0	41.1	44.2	46.0
d	MIN	18.0	21.1	26.0	29.0	32.4	35.5	38.6	42.0	44.7
L	MAX	14B	148	148	169	169	200	200	200	200

MIL-DTL-38999 Series I Connectors

Standard Tail Attachment (for GJB599I Series and Series II Electrical Connectors)

This type of attachment complies with the Chinese military standard GJB1784A, equivalent to the U.S. military standard MIL-C-85049.

GJB1784A Product Mark Code

$\frac{HL}{1}$ $\frac{J1784A/}{2}$ $\frac{27-}{3}$ $\frac{14}{4}$ $\frac{N}{5}$

1—Qinzhou Hanglong Electronics Co., Ltd. Corporate Name

2—Basic component number*

3—Detailed specification number*

Type 27-A

Tail nut

49—Type B

Vertical cable clamp

Type 47-C

Bend cable clamp

Type 62-D

Shielded termination tail accessory (prefix 'T' should be added before the basic component number)

62-Heat shrink sleeve tail accessory 01-grounded compression type 06-spring wire guard type

4—Shell sequence number

Shell sequence number	08	10	12	14	16	18	20	22	24
Adapted to the GJB599I series complete body number	09	11	13	15	17	19	21	23	25
Adaptation of GJB599 II Series Case Number	08	10	12	14	16	18	20	22	24

5—Shell coating: W-Cadmium-plated military green N-Chemical nickel plating S-Stainless steel passivation C-Nickel-chromated

F1-Sand-coated nickel C-Zinc-nickel alloy black (black chrome) C-Oxidized military green C2-Oxidized black

Note: 1. The model designations of the Chinese military standard GJB1784A and the U.S. military standard ML-C-85049 are identical except for their basic component numbers. The basic component number for GJB1784A is "J1784A", while the primary designation code for ML-C-85049 is "M85049". These two standards are interchangeable.

2. The accessory must be ordered separately. If the quantity matches that of the compatible plug and socket, the abbreviated code A, B, C, or D for the rear accessory may be added directly after the corresponding plug and socket model. These abbreviations are for user ordering and production management purposes only.

outline dimension

J1784A/06-Spring Tail Attachment for the First Guard Wire

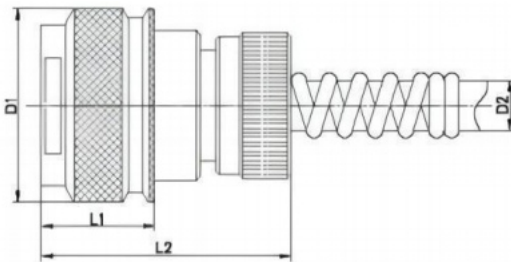

Model	D1	D2	L1	L2
J1784A/06-0BN	19.0	7.0	14.8	35
J1784A/06-10N	21.5	10.0	14.8	35
J1784A/06-12N	25.4	13.0	14.8	37
J1784A/0B-14N	27.5	15.0	14.8	37
J1784A/06-16N	31.5	18.0	14.8	37
J1784A/06-18N	35.5	20.0	14.8	40
J1784A/06-20N	38.0	23.5	14.8	40
J1784A/06-22N	42.0	26.5	14.8	45
J1784A/06-24N	44.5	29	14.8	45

MIL-DTL-38999 Series I Connectors

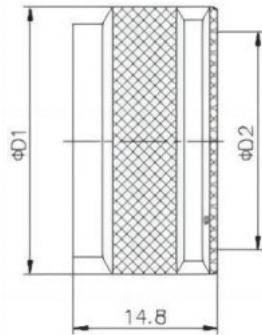

J1784A/27- (HA type)
caudal cap

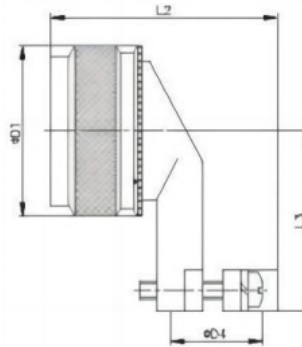

J1784A/47- (HC type)
bend cable clamp

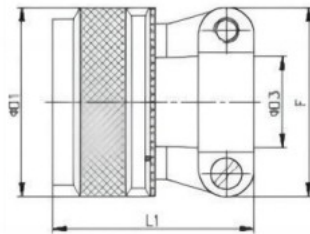

J1784A/49- (HB type)
vertical cable clamp

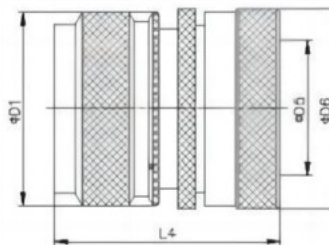

TJ1784A/62- (HD type)
shielded termination tail accessory

Number		08	10	12	14	16	18	20	22	24
D1	MAX	19.0	21.5	25.4	27.5	31.5	35.5	38.0	42.0	44.5
D2	MAX	7.0	10.5	13.4	16.5	19.7	22.4	25.6	28.8	31.9
D3	MIN	2.49	3.87	4.83	6.6	7.19	8.26	8.71	9.68	10.62
	MAX	5.94	5.94	8.33	11.61	15.6	16.1	17.73	20.9	21.66
D4	MIN	3.2	4.0	4.8	5.5	6.4	7.9	9.5	10.3	14.3
	MAX	6.4	9.5	11.1	14.3	15.9	19.1	22.2	23.8	25.4
D5	MAX	7.0	9.7	12.8	14.9	18.0	20.0	23.2	26.3	28.8
D6	MAX	17.0	19.9	23.1	26.3	29.5	32.5	35.7	38.9	42.0
F	MAX	20.0	20.0	23.4	26.6	30.6	34.0	35.8	38.0	40.6
L1	MAX	23.4	23.4	23.4	27.8	27.8	27.8	27.8	29.9	29.9
L2	MAX	29.0	32.0	33.5	36.5	38.5	41.5	44.5	46.0	48.0
L3	MAX	25.0	26.0	27.5	31.0	32.5	34.0	34.5	36.5	43.5
L4	MAX	31.2	31.2	31.2	33.2	33.2	33.2	36.2	36.2	36.2

J1784A/62-Heat-shrink sleeve tail attachment

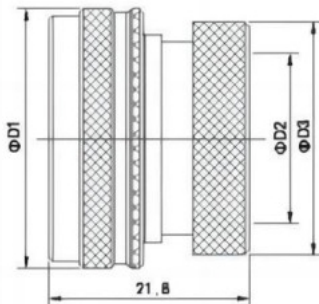

Model	D1	D2	D3
J1784A/62-	19.0	6.7	11.5
08NJ1784A/62-	21.5	9.9	14.6
10NJ1784A/62-	25.4	12.8	17.6
12NJ1784A/62-	27.5	16.0	21.2
14NJ1784A/62-	31.5	19.2	24.4
16NJ1784A/62-	35.5	21.4	26.4
18NJ1784A/62-	38.0	24.6	30.9
20NJ1784A/62-	42.0	27.7	33.8
22NJ1784A/62-	44.5	30.5	36.8

24N

MIL-DTL-38999 Series I Connectors

J1784A/01-Grounding and Tensioning Tail Attachment

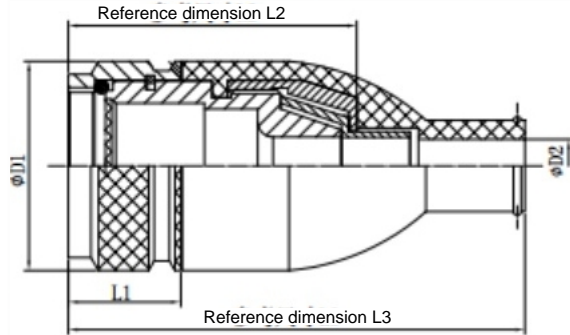

Model	D1	D2	L1	L2	L3
J1784A/01-0BN	19.0	7.0	14.8	35.0	60
J1784A/01-10N	21.5	10.0	14.8	35.0	60
J1784A/01-12N	25.4	13.0	14.8	37.0	65
J1784A/01-14N	27.5	15.0	14.8	37.0	75
J1784A/01-16N	31.5	18.0	14.8	37.0	75
J1784A/01-18N	35.5	20.0	14.8	40.0	75
J1784A/01-20N	38.0	23.5	14.8	40.0	75
J1784A/01-22N	42.0	26.5	14.8	45.0	75
J1784A/01-24N	44.5	29.0	14.8	45.0	75

TJ1784A/62-NB (HE type) straight-clamp wire-shielded rear attachment

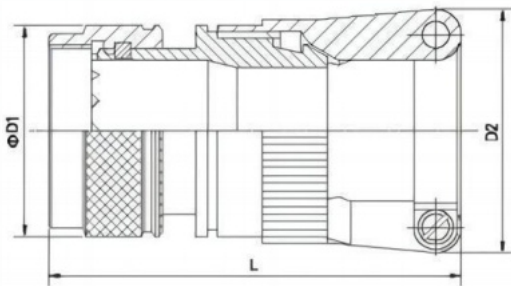

Model	D1	D2	L
TJ1784A/62-D8NB	19.0	10.4	39.0
TJ1784A/62-10NB	21.5	22.5	38.0
TJ1784A/62-12NB	25.4	25.7	38.0
TJ1784A/62-14NB	27.5	28.9	46.0
TJ1784A/62-16NB	31.5	32.1	46.0
TJ1784A/62-18NB	35.5	35.3	46.5
TJ1784A/62-20NB	38.0	38.4	51.3
TJ1784A/62-22NB	42.0	41.6	56.6
TJ1784A/62-24NB	44.5	44.8	57.3

J1784A/18A-xxN

$\frac{J1784A/}{1}$ $\frac{18A}{2}$ $\frac{-25}{3}$ $\frac{N}{4}$ $\frac{09}{5}$ $\frac{A}{6}$

1—Basic component number: J1784A

2—Detailed specification number: 18A—Straight shielded cable clamp

(for D38999I and II series) 3—Shell number: see Table 1

4—Shell coating: N—Chemical nickel plating, W—Cadmium plating (military green), S—Stainless steel passivation

5—Wire exit diameter code: Refer to Table 2

6—Length encoding: see Table 3

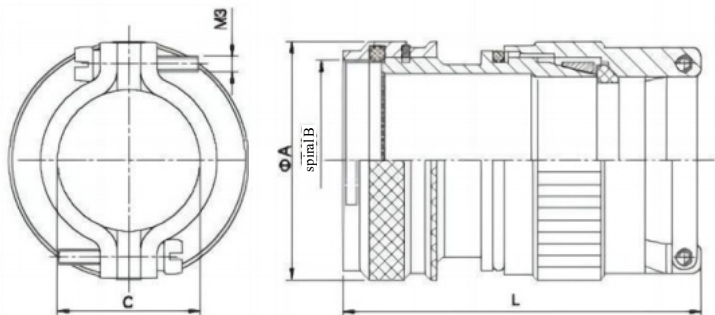

Table 1

Shell number	Select wire diameter code	A	Screw thread B
9	01~02	19.0	0.4375-28UNE
11	01-03	21.5	0.5625-24UNE
13	02-04	25.4	0.6875-24UNE
15	02-05	27.5	0.8125-20UNE
17	02~06	31.5	0.9375-20UNE
19	03~07	35.5	1.0625-18UNE
21	03~08	38.0	1.1875-18UNE
23	03~09	42.0	1.3125-18UNE
25	04~10	44.5	1.4375-18UNE

MIL-DTL-38999 Series I Connectors

Table 2

Outlet diameter number	Dimension range (C)
01	1.57~3.18
02	3.18~6.35
03	6.35~9.53
04	9.53~12.7
05	12.7~15.88
06	15.88~19.05
07	19.05~22.23
08	22.23~25.4
09	25.4~28.58
10	28.58~31.75

Table 3

Shell number	RLE	L
9~25	Standard provincial roads are not marked	62.7
9-25	A	88.1
15-25	B	113.5
21-25	C	138.9

J1784A/49-xxN (short)

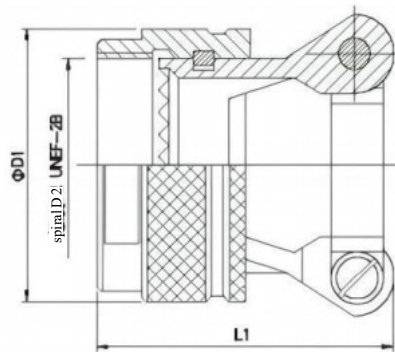

Attachment type	D1	Thread D2	L1
J17B4A/49-10N (short)	21.5	0.5625-24	20.8
J17B4A/49-12N (short)	25.4	0.6875-24	19
J17B4A/49-14N (short)	27.5	0.8125-20	25.2
J17B4A/49-16N (short)	31.5	0.9375-20	25.3
J17B4A/49-18N (short)	35.5	1.0625-18	26.7
J1784A/49-20N (short)	38.0	1.1875-18	26.8
J1784A/49-22N (short)	42.0	1.3125-18	32

MIL-DTL-38999 Series I Connectors

TJ1784A/62-xxNC-xx

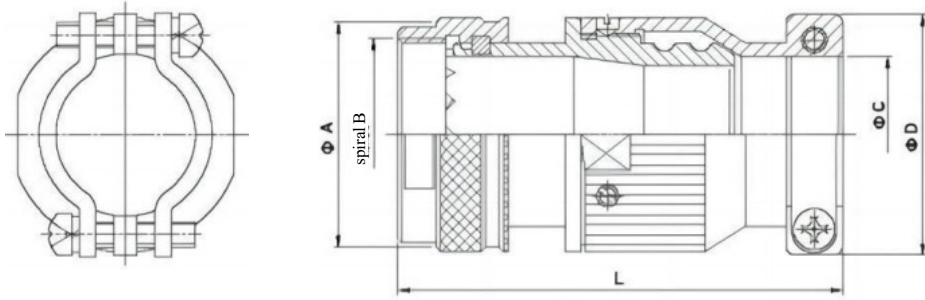

Attachment type	A	Screw thread BUNE	C	D	L
TJ1784A/62-0BNC-08	19.0	0.4375-2B	B	20	39
TJ1784A/62-10NC-08	21.5	0.5625-24	B	20	39
TJ1784A/62-10NC-10			10	20	40
TJ1784A/62-12NC-10	25.4	0.6875-24	10	20	40
TJ1784A/62-12NC-12			12	25	46.5
TJ1784A/62-14NC-12	27.5	0.8125-20	12	25	46.5
TJ1784A/62-14NC-14			14	27	46.5
TJ1784A/62-14NC-16			16	27	46.5
TJ1784A/62-16NC-16	31.5	0.9375-20	16	27	46.5
TJ1784A/62-16NC-19			19	32	46.5
TJ1784A/62-18NC-19	35.5	1.0625-18	19	32	46.5
TJ1784A/62-18NC-22			22	33	46.5
TJ1784A/62-20NC-22	38.0	1.1875-18	22	33	46.5
TJ1784A/62-20NC-25			25	36.5	46.5
TJ1784A/62-22NC-25	42.0	1.3125-18	25	36.5	46.5
TJ1784A/62-22NC-28			28	40	46.5
TJ1784A/62-24NC-28			28	40	46.5
TJ1784A/62-24NC-31	44.5	1.4375-18	31	44	46.5

MIL-DTL-38999 Series I Connectors

Special Tail Attachment (for GJB599I Series and Series II Electrical Connectors)

This type of tail attachment is specially designed for clamping shielded cables with shielding nets, available in two main types: straight and curved. The attachment can be optionally equipped with a TiNi alloy memory ring that contracts when heated, tightly securing the shielding net at the tail end, thereby achieving true 360° electromagnetic shielding.

◆ Thermal shrinkage of Ti-Ni alloy memory rings: The rings can be heated using either a dedicated resistance heater (which applies current through their inherent resistance) or a hot air gun. When the temperature indicator on the ring changes from green to black, indicating complete contraction, the temperature reaches approximately 165°C, and heating should be stopped. Ensure even heat distribution during the process. Electric heating requires about 4-5 seconds, while hot air gun heating takes 45 seconds to 1 minute.

Product logo code

HL D38999 I 15 FJA 00 F A -05
 1 2 3 4 5 6 7 8 9

1—Taizhou Hanglong Electronics Co., Ltd. Corporate Name

2 1. Military Standard Code 3—I (General Use for Series GJB599I and II)

4—Shell sequence number

Shell sequence number	09	11	13	15	17	19	21	23	25
Adapt to I-series housing numbers	09	11	13	15	17	19	21	23	25
Adaptation to Series II Case Number	0B	10	12	14	16	18	20	22	24

5— Attachment type: FJA, FJC, FJE

6. Structural Form: 00-Straight Tail Attachment; 90-90° Bend Attachment

7 1. Shell coating: B-Cadmium-plated military green
 E-Stainless steel passivation F-Chemical nickel plating

8— Titanium-nickel ring: No marking – No titanium-nickel ring. A-Titanium-nickel ring (optional, applicable only to FJA and FJC models)

9—Outlet diameter or titanium-nickel ring specifications

The diameter of the outlet is marked when there is no titanium-nickel ring.

Specify the titanium-nickel ring specifications when optional

outline dimension

Vertical attachments (D38999I—FJA00)

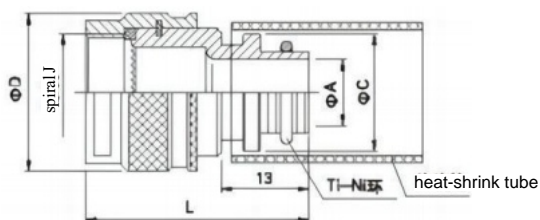

Bend-type attachment (D38999I-FJA90)

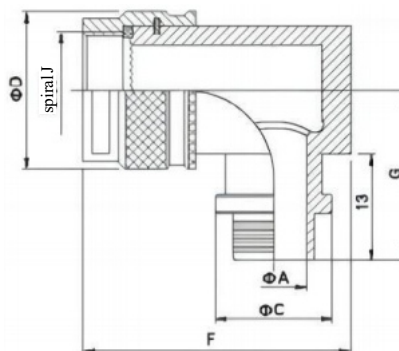

MIL-DTL-38999 Series I Connectors

Order number	Shell sequence number	Ti-Ni ring specifications	Screening grid specification Nominal diameter of tin-plated copper wire	A Outlet diameter		C		F	L	D	G	Thread J UNE-2B
				Vertical	Bent	Vertical	Bent					
1	08	TF-04	6×10(0.15~0.20)	6.3	6.3	14.0	14.0	36.3	31.7	19.0	26	0.4375-28
		TR-05	10×16(0.15~0.20)	7.8	7.9	15.5	16.0					
		TR-06	10×16(0.15~0.20)	9.5	9.5	17.1	15.0					
2	11	TF-04	6×10(0.15~0.20)	6.3	6.3	14.0	14.0	37.8	31.7	21.5	26	0.5625-24
		TF-05	10×16(0.15~0.20)	7.9	7.9	15.5	15.5					
		TF-06	10×16(0.15~0.20)	8.5	9.5	17.1	17.1					
		TF-07	10×16(0.12~0.20)	11.1	11.1	18.7	18.0					
		TF-08	16×24(0.12~0.25)	12.7	12.7	20.3	18.0					
3	13	TF-04	6×10(0.15~0.20)	6.3	6.3	14.0	14.0	43.3	31.7	25.4	29	0.6875-24
		TF-05	10×16(0.15~0.20)	7.9	7.9	15.5	15.5					
		TF-06	10×16(0.15~0.20)	9.5	9.5	17.1	17.1					
		TR-07	10×16(0.12~0.20)	11.1	11.1	18.7	18.7					
		TH-0B	16×24(0.12~0.25)	12.7	12.7	20.3	20.3					
		TF-10	16×24(0.10~0.30)	16.0	16.0	23.5	23.0					
4	15	TF-05	10×16(0.15~0.20)	7.9		15.5		45.1	33.6	27.5	29	0.8125-20
		TR-06	10×16(0.15~0.20)	9.5	9.5	17.1	17.1					
		TR-07	10×16(0.12~0.20)	11.1	11.1	18.7	18.7					
		TH-0B	16×24(0.12~0.25)	12.7	12.7	20.3	20.3					
		TF-10	16×24(0.10~0.30)	16.0	16.0	23.5	23.5					
		TF-12	16×24(0.10~0.30)	19.0	19.0	26.7	26.5					
5	17	TR-05	10×16(0.15~0.20)	7.9		15.5		48.8	33.6	31.5	33	0.9375-20
		TR-06	10×16(0.15~0.20)	9.5	10.5	17.1	17.1					
		TF-07	10×16(0.12~0.20)	11.1	11.1	18.7	18.7					
		TH-08	16×24(0.12~0.25)	12.7	12.7	20.3	20.3					
		TF-10	16×24(0.10~0.30)	16.0	16.0	23.5	23.5					
		TF-12	16×24(0.10~0.30)	19.0	19.0	26.7	26.7					
6	19	TF-0B	16×24(0.12~0.25)	12.7	12.7	20.3	20.3	51.6	33.6	35.5	33	1.0625-18
		TF-10	16×24(0.10~0.30)	16.0	16.0	23.5	23.5					
		TR-12	16×24(0.10~0.30)	19.0	19.0	26.7	26.7					
		TR-14	24×30(0.10~0.30)	22.2	22.2	30.0	30.0					
		TH-16	24×30(0.10~0.30)	25.4	25.4	33.0	32.0					
7	21	TF-0B	16×24(0.12~0.25)	12.7	12.7	20.3	20.3	53.8	33.6	38.0	39	1.1875-18
		TF-10	16×24(0.10~0.30)	16.0	16.0	23.5	23.5					
		TF-12	16×24(0.10~0.30)	19.0	19.0	26.7	26.7					
		TR-14	24×30(0.10~0.30)	22.2	22.2	30.0	30.0					
		TH-16	24×30(0.10~0.30)	25.4	25.4	33.0	33.0					
		TH-18	30×40(0.10~0.30)	28.5		36.2	2					
8	23	TF-10	16×24(0.10~0.30)	16.0	16.0	23.5	23.5	56.3	33.6	42.0	39	1.3125-18
		TR-12	16×24(0.10~0.30)	19.0	19.0	26.7	26.7					
		TF-14	24×30(0.10~0.30)	22.2	22.2	30.0	30.0					
		TF-16	24×30(0.10~0.30)	25.4	25.4	33.0	33.0					
		TH-18	30×40(0.10~0.30)	28.5	28.5	36.2	36.2					
		TF-20	30×40(0.10~0.30)	31.8	2	39.4						
9	25	TR-10	16×24(0.10~0.30)		16.0		23.5	61.8	31.8	44.5	44	1.4375-18
		TF-12	16×24(0.10~0.30)	19.0	19.0	26.7	26.7					
		TF-14	24×30(0.10~0.30)	22.2	22.2	30.0	30.0					
		TF-16	24×30(0.10~0.30)	25.4	25.4	33.0	33.0					
		TF-18	30×40(0.10~0.30)	28.5	28.5	36.2	36.2					
		TH-22	30×40(0.10~0.30)	35.0	35.0	42.5	42.0					

MIL-DTL-38999 Series I Connectors

D38999I xxFJA90F03

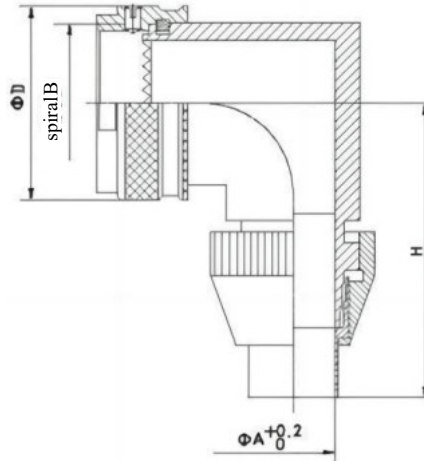

Shell number	A Outlet diameter	Thread B UNEF-2B	D	H
11	10	0.5625-24	18.6	39
13	10	0.6875-24	21.8	39
15	10, 16	0.8125-20	25	43
17	12.7, 16, 18	0.9375-20	28.2	43
23	19	1.3125-20	37.5	45

D38999I xxFJC00

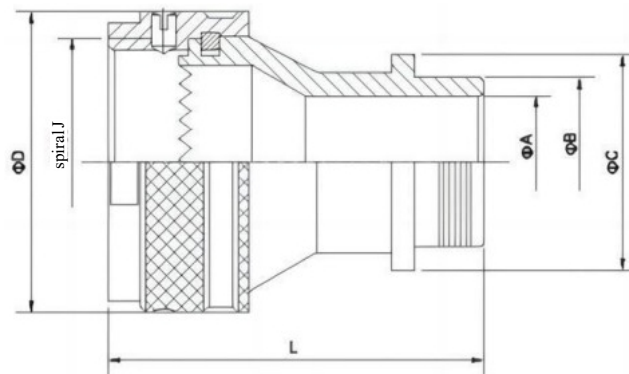

Shell number	A	B	C	D	Screw thread J UNE	L	Ti-Ni ring specifications
11	8.3	11	15	21.5	0.5625-24	29	TH-05
13	10	12.7	16.6	25.4	0.6875-24	29	TH-06
15	11.1	14.3	18.5	27.5	0.8125-20	29	TH-07
17	13.1	15.9	19.8	31.5	0.9375-20	29	TH-0B
19	16.2	19	23	35.5	1.0625-18	29	TH-10
21	16.2	19	23	38.0	1.1875-18	29	TH-10
23	19.5	22.2	26.2	42.0	1.3125-18	29	TH-12
25	19.5	22.2	26.2	44.5	1.4375-18	29	TH-12

MIL-DTL-38999 Series I Connectors

D38999I xxFJE00

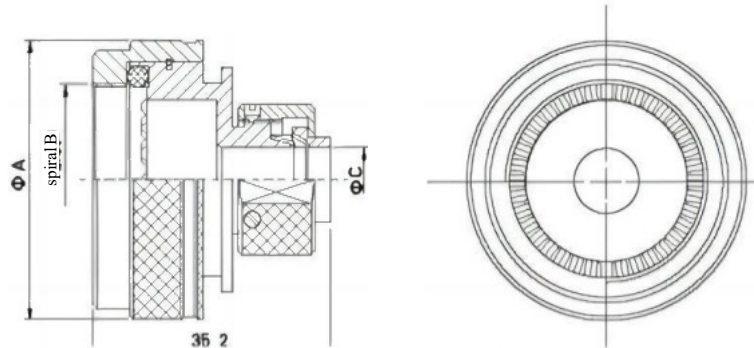

Shell number	A	Thread Day UNE	C Outlet diameter
09	22	0, 4375-28	6, 3, 7, 9, 9, 5
11	25	0. 5825-24	6. 3, 7. 9、 9. 5, 11. 1, 12. 7
13	28	0. 6875-24	6. 3. 7. 0、 9. 5. 11. 1、 12. 7、 16
15	32	0. 8125-20	7. 8, 9. 5、 11. 1、 12. 7, 16、 19
17	35	0. 9375-20	7. 9, 9. 6, 11. 1, 12. 7、 16, 19、 22. 2
23	44	1. 3125-18	16. 18, 22. 2, 26. 4、 28. 6, 31. 8
25	47	1. 4375-18	19, 22. 2、 25. 4. 28. 5、 31. 8、 35

Roundplate with rubber pad

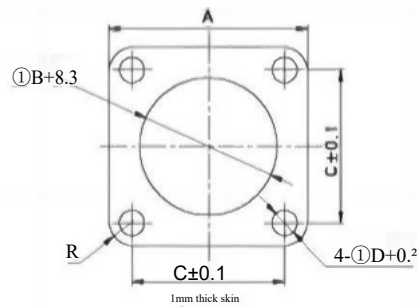

Adapt shell number	Code for square plate rubber pad	Conductive square disc rubber pad code	A	B	C	D	R
0B	21E8. 701. 848	21E8. 701. 860	23. 8	14. 8	18. 26	3. 3	3. 2
11	21E8. 701. 851	21E8. 701. 852	26. 3	18. 0	20. 62	3. 3	3. 2
13	21EB. 701. 853	21EB. 701. 854	28. 7	21. 8	23. 01	3. 3	3. 2
15	21EB. 701. 855	21EB. 701. 858	31. 1	25. 0	24. 61	3. 3	3. 2
17	21EB. 701. 857	21EB. 701. 858	33. 4	28. 2	26. 97	3. 3	3. 2
19	21EB. 701. 85B	21EB. 701. 880	36. 6	30. 9	29. 36	3. 3	3. 2
21	21EB. 701. 861	21EB. 701. 882	39. sun	34. 0	31. 75	3. 3	3. 2
23	21EB. 701. 863	21EB. 701. 864	43. 0	37. 2	34. 93	3. 8	3. 7
25	21EB. 701. 865	21EB. 701. 866	46. 1	40. 4	38. 10	3. 8	3. 7

MIL-DTL-38999 Series II Connectors

This series of round electrical connectors complies with GJB599A (MIL-DTL-38999K) Series II standards, featuring snap-fit quick connections with EMI/RFI shielding. The contact parts are press-fitted and detachable, but not designed for diagonal insertion. Among all GJB 599A series, it boasts the smallest size, lightest weight, and shortest housing. As a lightweight connector, it is suitable for applications where high-intensity vibrations are not required or exposure to harsh wind, sand, and moisture is not a concern.

Product Logo Code

HL JY 27472 T 14 F 35 P N
1 2 3 4 5 6 7 8 9

1—Taizhou Hanglong Electronics Co., Ltd. Corporate Name

2. Main Title of a Circular Electrical Connector

3 Category 1: 27473-Plug (Class T only) 27484-Shielded Plug (Class T only)

27472-Wall-mounted Square Tray Pre-installed Socket (Class T only) 27513-Box-type Square Tray Pre-installed Socket (Class E only) 27497-Wall-mounted Square Tray Post-installed Socket (Class T only) 27508-Box-type Square Tray Post-installed Socket (Class E only) 27474-Nut-mounted Socket (Class T available) Class E non-threaded (custom order required)

4— Shell category: T-Threaded tail with rear attachment stop teeth, allowing installation of rear attachments E-Non-threaded tail, no rear attachment stop teeth, preventing installation of rear attachments

5 – Shell numbers: 08,10,12,14,16,18,20,22,24

6 1. Shell coating: B-aluminum alloy shell, cadmium-plated military green

C-Aluminum alloy housing, anodized

F-aluminum alloy housing, electroless nickel plating

E-Stainless steel shell, passivated

F1 one spray sanding nickel

C, black zinc-nickel alloy (black chrome)

C, military green

C2 monochromic black

7—Contact arrangement: Refer to the "Contact arrangement" diagram for details

8	P-type crimping pin, 500 pull-out cycles	PH-welding broadcast needle	PC-Short Printed Circuit Board Spreading Needle	PL-long printed circuit board spread needle
	H-1 crimping pin, 1500 insertion and removal cycles	HH – Welding Pin	HC-short printed circuit board pin	HL-long printed circuit board pin
	S-crimping socket, 500 insertion and removal cycles	SH-Welding socket	SC-Short Circuit Board Insert	SL-Long Printed Circuit Board Insert
	J-1 crimping hole, 1500 crimping cycles	H one welding hole	JC short printed circuit board via	JL long printed circuit board holes

CD-Externally a pin, internally a hole, with the flange located outside the compartment (wall-penetrating seat)

DC-Externally a hole, internally a needle, with the flange located outside the compartment (wall-penetrating seat)

9 N: Normal key position A.B.C, D.E: Variable key position

Note: The National Standard GJB599A and the U.S. Standard ML-DTL-38998K share identical model names except for their primary designations. GJB599A is designated as 'JY', while MIL-DTL-38998K is labeled 'MS'. Both standards are interchangeable.

Product Technical Characteristics

I. Environmental Conditions for Use

Operating temperature: Class B-65°C~+175°C

Class C, E, and F-Salt spray resistance at-65°C to +200°C: Test performed according to GJB 1217 Method 1001

Category B: 500 hours; Category E: 1000 hours; Category F: 4 8 hours; Category C: 9 6 hours

Relative humidity: 98% at 40°C

Working height: ≤30,480 m

The electrical connector also features excellent moisture resistance, salt spray resistance, mold resistance, and rainproof performance.

sand and dust resistance



MIL-DTL-38999 Series II Connectors

II. Electrical Characteristics

Contact resistance and rated current of contact

Contact specifications	Working diameter mm	Contact resistance mΩ	Rated current A
22D ⁴	φ 0.76	≤12	5
20#	①1.00	≤5	7.5
16@	①1.60	≤2.5	13
12#	φ 2.40	≤1.5	23

Electromagnetic interference shielding:

The minimum attenuation is 45dB at frequencies ranging from 100MHz to 1 GHz.

Withstand Voltage (V)

Job level	M	≈	II
Sea level	1300	1800	2300
21000m	800	1000	1000

● Different contact arrangements have different working levels. See contact arrangement for details.

insulation resistance :

Normal condition >5000M

Humid and hot conditions ≥100MQ

0 Shell-to-shell electrical

continuity:

Class B ≤2.5 mΩ

Class F: ≤1.0 mΩ

Category E: ≤5.0 mΩ

III. Mechanical Properties

Shell: Aluminum alloy, Stainless steel Contact type: gold-plated copper alloy, crimped type, soldered type, printed circuit board type

Coating: B class cadmium-plated military green C class anodized Mechanical lifespan: ≥500 insertions and extractions

Class E stainless steel, annealed; Class F nickel-plated Vibration: random vibration, frequency 100~1000 Hz, power spectral density 1 G2/Hz

Insulator: Thermosetting plastic

Impact: 3ms half-sine wave, acceleration peak 300g

Sealing Body and Sealing Ring: Silicone Rubber Material

IV. Marking of Pressed Contact Parts

Contact specifications	Diameter mm	Pin Color Label	Plug color code	Inner diameter of the wire roll mm	Outer diameter of wire roll mm	Adaptation Lead Section mm ²	Adapt to US standard cable AWG	Insulated conductor outer diameter (mm)	Tool code for removal
22D ⁴	0.76	Orange, blue, and black	Orange, green, and yellow	0.85	1.20	0.08 0.125 0.2 0.3	28 26 24 22	0.76~1.37	MB1969/ 14-01
20#	1.00	Orange, blue, and orange	Orange, green, and purple	1.17	1.78	0.2 0.3 0.5	24 22 20	1.02~2.11	M81969/ 14-10
16#	1.60	Orange, blue, and yellow	One is green, one is gray.	1.88	2.82	0.5 0.8 1.0 1.2	20 18 16	1.65~2.77	MB1969/ 14-03
12 ⁴	2.40	Orange, blue, and green	Orange, green, and white	2.49	3.84	2.0 3.0	14 12	2.46~3.61	MB1969/ 14-04

Note: The required crimping tools and their usage instructions are provided in Appendix 1 (Page P103).

MIL-DTL-38999 Series II Connectors

5. Contact Arrangement (Visual Diagram of Needle Insulator Insertion Surface)



DB-35 M



QB-98 I

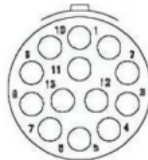

10-35 M

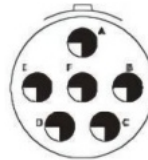

10-98 I

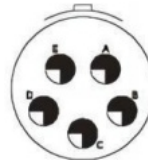

10-051

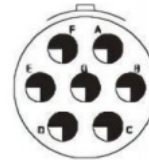

12-35 M

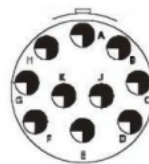

12-98 I

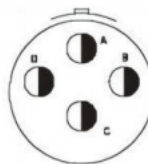

12-04 I

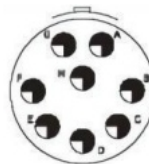

12-08 I

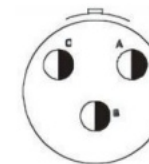

14-35 M

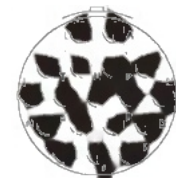

14-18 I

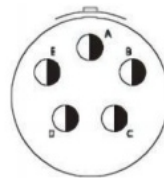

14-05 II

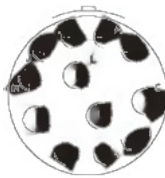

14-97 I

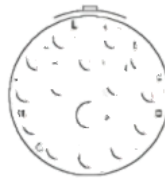

14-15 I

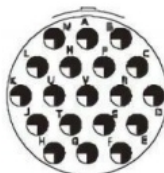

16-19 I

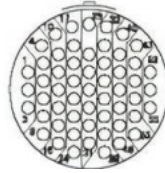

16-35 M

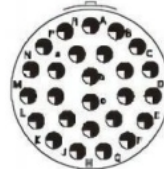

18-26 I

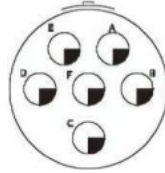

18-08 I

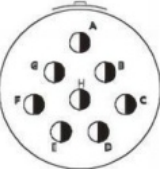

18-08 II

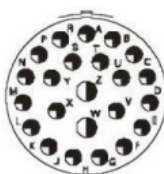

16-99 I

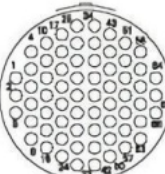

18-35 M



18-32 I



18-28 I

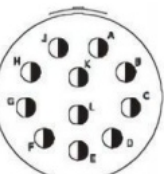

18-11 II

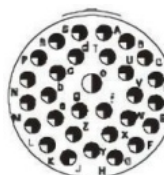

1B-301

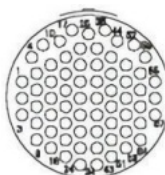

1B-45 M

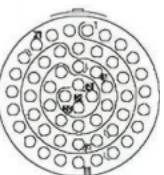

18-53 M

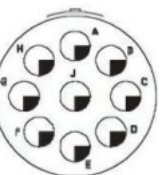

18-9B I

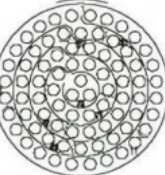

20-35 M

MIL-DTL-38999 Series II Connectors

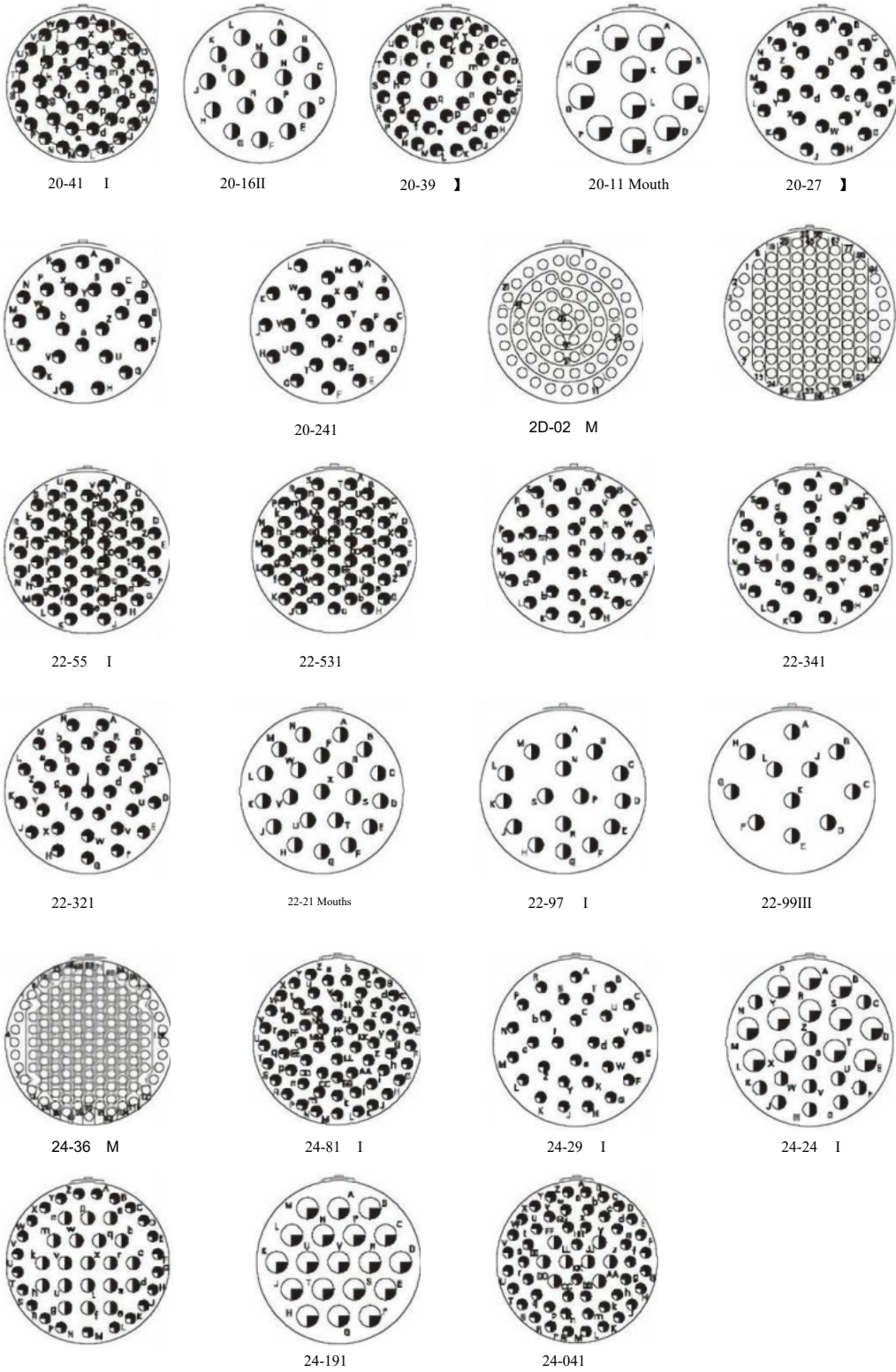

Note: Contact part diameter marking □22D# ●20#016# 12#

MIL-DTL-38999 Series II Connectors

VI. Preventing Key Misinsertion

socket key angle

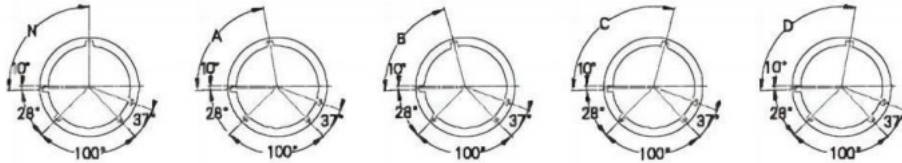

plug key angle

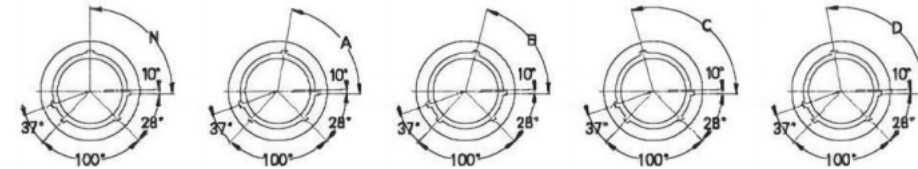

Key code	0B	10	12	14	16	18	20	22	24
N	100°	100°	100°	100°	100°	100°	100°	100°	100°
A	B2°	86°	B0°	79°	82°	82°	82°	85°	85°
B		72°	68°	66°	70°	70°	70°	74°	74°
c		128°	132°	134°	130°	130°	130°	126°	126°
D	118°	114°	120°	121*	118°	118°	118°	115°	115°

VII. Dimensions

1. Plug JY27473/JY27484

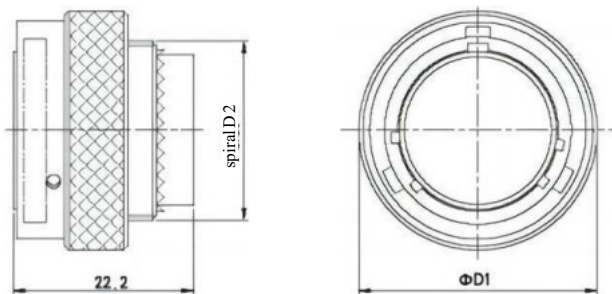

Shell number	D1	Thread D2 UNEF-2A
08	19.00	0.4375-28
10	21.80	0.5625-24
12	26.20	0.6875-24
14	29.30	0.8125-20
16	32.50	0.9375-20
18	35.70	1.0625-18
20	38.80	1.1875-18
22	41.68	1.3125-18
24	44.86	1.4375-18

MIL-DTL-38999 Series II Connectors

2. Wall-Mounted Square Socket JY27472/JY27497

Wall-mounted square tray with pre-installed socket (JY27472)

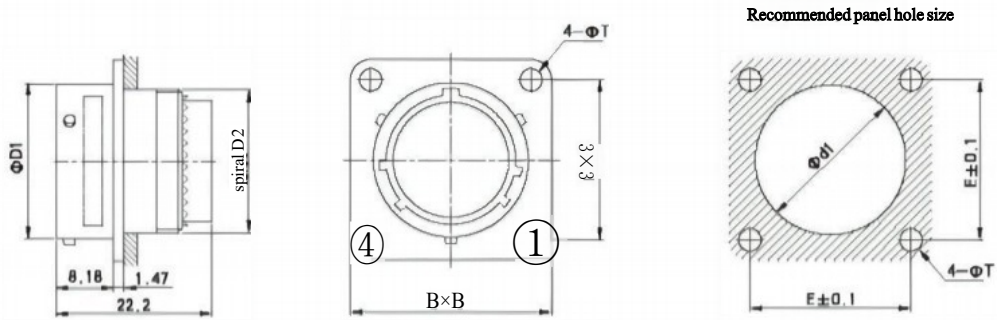

Wall-mounted square plate with rear-mounted socket (JY27497)

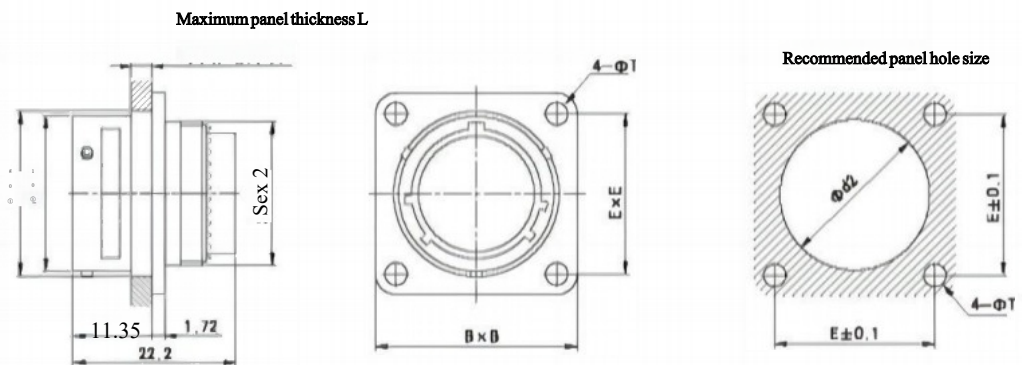

Complete Body Number	D1	Thread D2 UNE-2A	D3	L (Max)	B	E	T	d1	d2
0B	12.00	0.4375-28	13.20	3.71	21.00	15.09	3.2	12.5	14.2
10	15.00	0.5825-24	16.14	3.71	24.10	18.26	3.2	15.5	17.5
12	19.05	0.6875-24	20.50	3.71	26.50	20.62	3.2	19.5	21.3
14	22.23	0.8125-20	23.60	3.71	28.90	23.01	3.2	21.5	25.0
16	25.40	0.9375-20	26.80	3.71	31.21	24.61	3.2	25.0	27.3
18	28.58	1.0825-18	30.00	3.71	33.60	26.97	3.2	28.0	31.3
20	31.75	1.1875-18	33.20	4.27	36.80	29.36	3.2	31.5	34.5
22	34.93	1.3125-18	36.35	4.27	40.00	31.76	3.2	34.6	37.5
24	38.10	1.4375-18	39.50	4.27	43.10	34.93	3.9	37.5	40.6

MIL-DTL-38999 Series II Connectors

3、 JY27513/JY27508 Box-Type Square Dish Socket

Pre-installed socket for box-type square tray (JY27513)

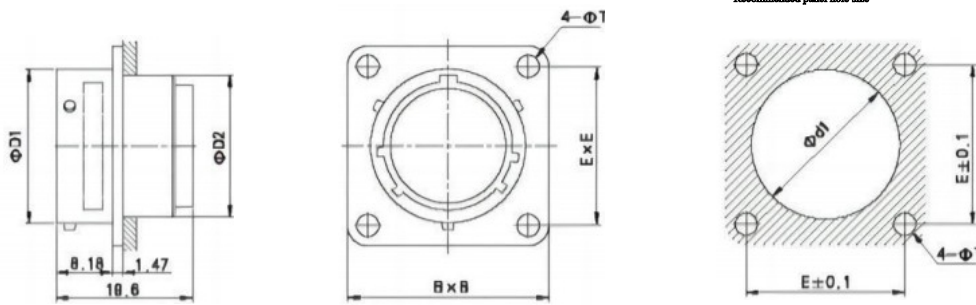

Box-type square plate with rear-mounted socket (JY27508)

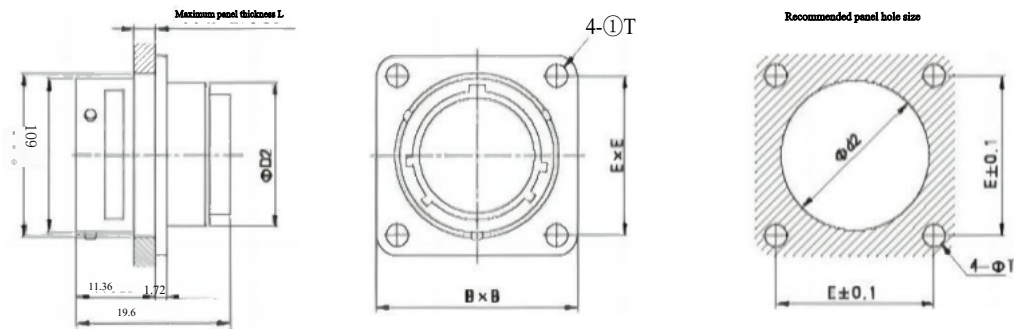

Shell number	D1	D2	D3	L (Max)	B	E	T	d1	d2
08	12,00	11,51	13,20	3,71	21,00	15,09	3,2	12,5	14,2
10	15,00	14,88	16,14	3,71	24,10	18,26	3,2	15,5	17,5
12	19,05	17,86	20,50	3,71	26,50	20,62	3,2	10,5	21,3
14	22,23	21,03	23,80	3,71	28,80	23,01	3,2	21,5	25,0
16	25,40	24,21	26,80	3,71	31,21	24,61	3,2	25,0	27,3
18	28,58	26,97	30,00	3,71	33,60	26,97	3,2	28,0	31,3
20	31,75	30,18	33,20	4,27	36,80	29,36	3,2	31,5	34,5
22	34,93	33,32	36,35	4,27	40,00	31,75	3,2	34,5	37,5
24	38,10	36,53	39,50	4,27	43,10	34,93	3,9	37,5	40,6

MIL-DTL-38999 Series II Connectors

4、 Nut Installation Socket JY27474

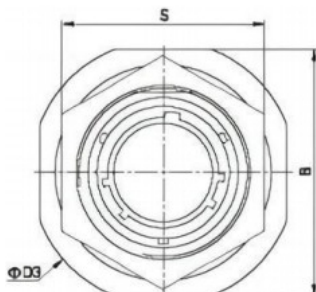
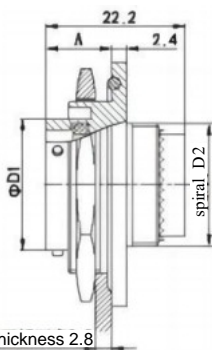

Recommended opening size for national standard boards

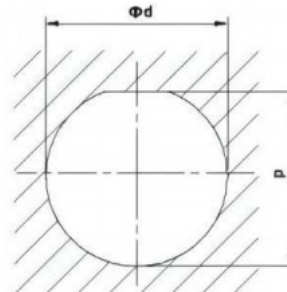

Maximum panel thickness 2.8

Shell number	D1	Thread D2 UNEF-2A	D3	A	B	S	d	P
0B	12.00	0.4375-28	34.95	11.1	31.75	27.40	22.46	21.0B
10	15.00	0.5625-24	38.10	11.1	34.95	30.61	25.58	24.26
12	19.05	0.6875-24	41.28	11.1	38.10	33.75	28.80	27.53
14	22.23	0.8125-20	44.45	11.1	41.28	36.96	31.98	30.6B
16	25.40	0.8375-20	48.23	11.1	46.24	40.10	35.15	33.86
18	28.58	1.0625-18	51.21	11.1	48.00	43.31	38.2B	37.06
20	31.75	1.1875-18	54.38	11.8	51.21	46.45	41.50	40.03
22	34.93	1.3125-18	57.53	11.8	54.36	51.23	44.68	43.21
24	38.10	1.4375-18	60.71	11.8	57.53	54.41	47.85	46.38

5、 Socket With Printed Circuit Board Contact

JY27497 socket

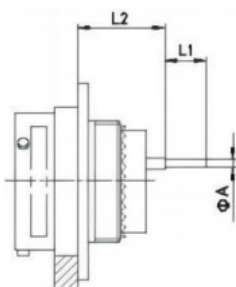

JY27474 socket

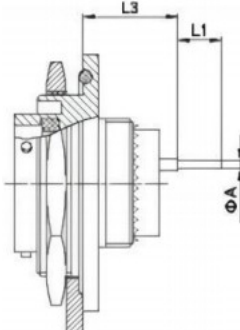

PCB contact specifications		L1	A
22D#	Long printed circuit board contact	8.5	0.7
	Short board contact	4.0	
20#	Long printed circuit board contact	8.5	0.7
	Short board contact	5.1	
16#	Long printed circuit board contact	8.5	1.15
	Short board contact	5.1	

Dimensions for installing contact pieces of different specifications		Luminous Number 0 B-10 -12-14-16-18	Case number 20-22-24
L2	When installing 22D# pins and drilling holes	13.40	13.40
	When installing 20# or 16# pins and sockets	13.57	13.57
L3	When installing 22D# pins and sockets	13.61	12.95
	When installing 20# or 16# pins and sockets	13.78	13.12

MIL-DTL-38999 Series II Connectors

8. Dimensions after plug and socket installation

Wall-mounted square tray with pre-installed socket (JY27472) / Socket head (JY27473)

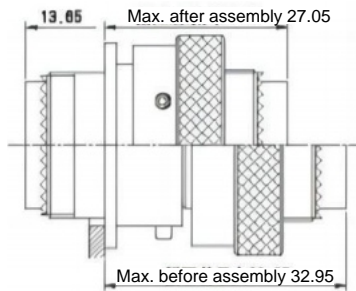

Wall-mounted square tray rear-mounted socket (JY27497) / Plug (JY27473)

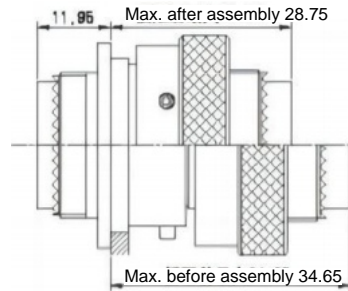

Pre-installed socket for box-type square tray (JY27513) / Socket head (JY27473)

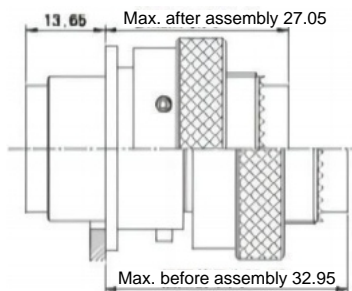

IX. Plug-in Broadcast Sealing Cap

Product logo code

H	JY27510	F	10	C	L
1	2	3	4	5	6

1—Taizhou Hanglong Electronics Co., Ltd. Corporate Name

2. Basic component number: JY27510-Plug sealing cover (corresponding to US military standard component number MS27510)

JY27511 – Socket Sealing Cover (Corresponding to US Military Standard component number MS27511)

3 — Surface coating: B-Cadmium-plated military green E-Stainless steel passivation F-Chemical nickel plating 4— Shell numbers: 08,10,12,14,16,18,20,22,24

5 1. Chain types: C-Stainless steel twisted chain N-Stainless steel twisted chain with rings S-Stainless steel wire rope R-Bronze wire rope A-No chains

6—Length marking: No marking-
Standard length L-Chain length is 127mm

The M chain has a length of 152.4mm (applicable only to JY27510)

The N-chain length is 177.8mm (applicable only to JY27510)

Note: 1. JY27511 denotes a composite material sealing cap, where the model is indicated by a "-" symbol in the absence of a coating.

2、 The sealing cap must be ordered separately and is not included with the connector.

MIL-DTL-38999 Series II Connectors

outline dimension

Plug seal cover JY27510 (MS27510)

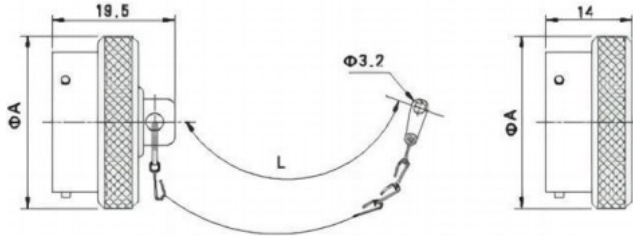

Socket sealing cap JY27511 (MS27511)

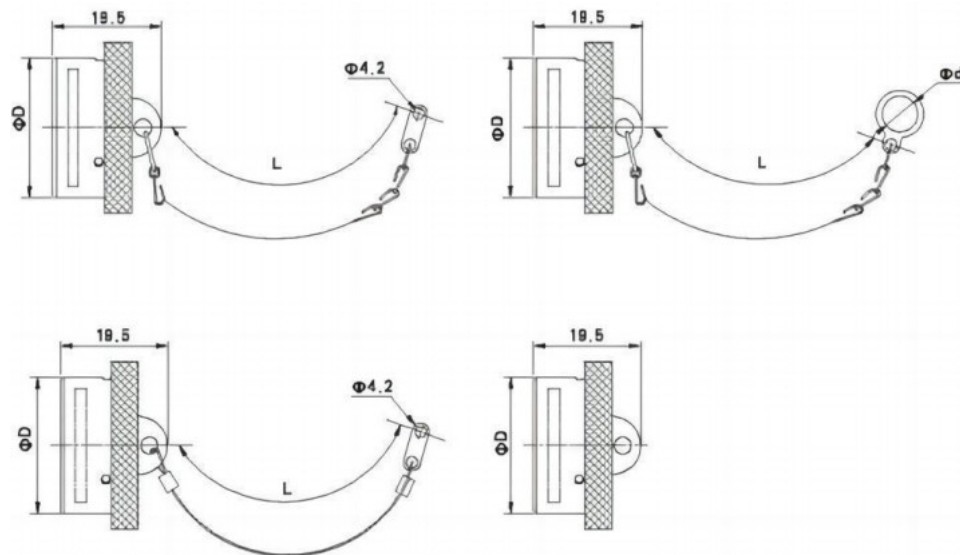

Filler number		08	10	12	14	16	18	20	22	24
A	MAX	18.2	21.5	25.4	28.7	31.7	35.0	38.1	41.4	44.4
D	MAX	18.5	21.7	25.3	29.0	31.6	34. B	38.0	41.1	44.2
d	MIN	22.6	26.0	29.0	32.4	35.5	38.6	42.0	44.7	48.5
L	MAX	148	148	148	169	169	200	200	200	200

MIL-DTL-38999 Series II Connectors

Caudal Appendage

Optional rear accessories are compatible with those of the GJB599I series.

Round plate with rubber pad

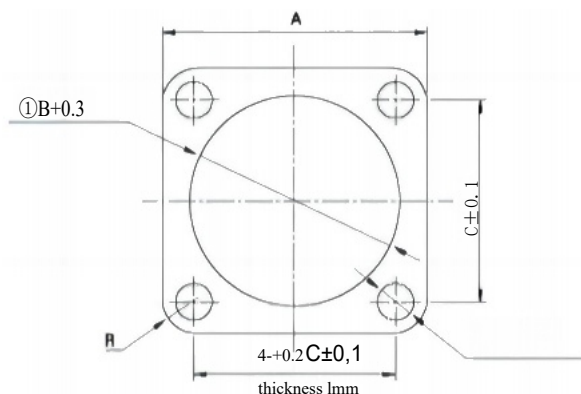

Hypocallus	Code for square plate rubber pad	Conductive square disc rubber pad code	A	B	C	D	R
0B	21EB. 701. 867	21EB, 701. 868	21. 1	13. 4	15, 00	3. 3	3. 2
10	21EB. 701. 88B	21EB, 701. 870	24. 2	16. 3	18, 26	3. 3	3. 2
12	21E8, 701, 871	21EB, 701. 872	28, 6	21. 5	20, 82	3, 3	3. 2
14	21EB. 701. 873	21EB. 701. 874	29. 0	24. 7	23. 01	3. 3	3. 2
18	21EB, 701, 875	21EB. 701. 876	31. 3	27. 0	24. 61	3. 3	3. 2
1B	21EB. 701. 877	21EB. 701. 878	33. 7	31. 0	26, 97	3. 3	3. 2
20	21EB. 701. 879	21EB. 701. 880	36. sun	34. 2	29. 38	3. 3	3. 2
22	21EB. 701. 881	21E8. 701. 882	40. 1	37. 4	31. 75	3. 3	3. 2
24	21EB. 701. 883	21EB. 701. 884	43. 2	40. 5	34, 93	4. 1	4. 0

MIL-DTL-38999 Series III Connectors

This series of round electrical connectors complies with GJB599A (ML-DTL-38999K) Series III standards, featuring three-thread quick-connect technology with anti-loosening mechanisms. The compact design offers lightweight construction, high contact density, electromagnetic shielding, detachable crimped contacts, and anti-slip pin insertion. Available in fire-resistant, aluminum alloy, and various coating options, the product demonstrates high-strength vibration resistance under high temperatures, making it ideal for harsh environments with sandstorms and humidity.

Product Logo Code

<u>HL</u>	<u>J599/</u>	<u>20</u>	<u>W</u>	<u>B</u>	<u>35</u>	<u>P</u>	<u>N</u>	<u>T</u>
1	2	3	4	5	6	7	8	9

1. Taizhou Hanglong Electronics Co., Ltd. enterprise name;

2 — Basic serial number

3 — Shell type: 11-Round socket 20-

Square socket 24-

Nut fastening so-

cket 26-Shielded

plug

4 — cladding material : W-

Cadmium-

plated military

green F-

Chemical nickel

plating S-Nickel

copper plating

K-Stainless st-

eel passivation

5 — Shell number: A to J

Index number

<u>09</u>	<u>11</u>	<u>13</u>	<u>15</u>	<u>17</u>	<u>19</u>	<u>21</u>	<u>23</u>	<u>25</u>
A	B	C	D	E	F	G	H	J

6. Contact arrangement: See the contact arrangement diagram for details.

7 P-pressing pin. 500 times of insertion and removal. PH-welding pin. PC-short printed circuit board pin. PL-long printed circuit board pin. H-crimping pin, 1500 insertion and removal cycles HH-soldering pin HC-short PCB pin HL-long PCB pin

S-crimped socket, 500 insertion/withdrawal cycles SH-soldered socket SC-short printed circuit board socket SL-long printed circuit board socket

J-Press-fit socket, withstand 1500 insertion/withdrawal cycles JH-Soldered socket JC-Short printed circuit board socket JL-Long printed circuit board socket

CD-Externally a pin, internally a hole, with the flange located outside the compartment (wall-penetrating seat)

DC-Externally a hole, internally a needle, with the flange located outside the compartment (wall-penetrating seat)

A-Special pin contact component B-Special socket contact component

8 N: Normal key positions A, B, C, D, E; 1: Variable key positions

9 T1 denotes the nut-tightening socket with double-flattened milling (not specified for standard models)

pour :

1、 The National Standard GJB599A and the U.S. Military Standard MIL-DTL-3899K share identical model names except for their primary designations. GJB599A is designated as 'J599' while MIL-DTL-3899K is labeled 'D38999', making them interchangeable.

2. Identification codes A and B denote electrical connectors employing contact components that differ from the non-standard configurations specified in GJB1611 (e.g., shielded, coaxial, or fiber optic contacts). These components must be ordered separately, with specific model specifications available in the section "Special Contact Components for GJB599 Series III".

3. The compatible sealing caps, tail attachments, and square disc rubber pads for this product series are detailed in pages P71-P84.



MIL-DTL-38999 Series III Connectors

Product technical characteristics

I. Environmental Conditions for Use

Temperature range: Class W: 65°C to +175°C

Class F, Class K: -65°C to +200°C

Seal: The plug-in connector complies with the requirements of MIL-DTL-38999K for low-pressure impregnation.

Wet heat: per MIL-DTL-38999K: 10 cycles in 24 hours

Salt spray: Test according to Method 1001 in GJB1217. Class W: 500h; Class F: 48h; Class K: 1000h

Fuel-resistant: Resistant to various fuels, coolants, and solvents

II. Electrical Characteristics

Voltage rating: (Vms)

Going	Sea level	At an altitude of 21,000 meters
M	1300	800
N	1000	600
I	1800	1000
II	2300	1000

Insulation resistance: greater than or equal to 5000 MΩ at 500Vdc

Conductivity of the housing: Class W: 2.5 mΩ; Class F: 1 mΩ; Class K: 5 mΩ

Amplidyromic: 65dB (Class F) at 10GHz

50dB (Class W) at 10GHz

85dB at 1GHz (Class F and Class W)

Note: Different contact arrangements have different operating conditions. See "Contact Arrangement" for details.

Contact resistance and rated current of contact

Contact specifications	Working diameter (mm)	Contact resistance (mΩ)	Rated current (A)
22D#	①0.76	<12	5
20#	φ 1.00	≤5	7.5
16*	①1.60	<2.5	13
12*	①2.40	≤1.5	23
10*	①3.15	<1.0	40

III. Mechanical Properties

Shell: Aluminum alloy, Stainless steel

Coating: W-cadmium plating, F-electroless nickel plating, K-stainless steel passivation

Insulator: thermoplastic or thermosetting material

Sealing body and sealing ring: silicone rubber

Contact: Gold-plated copper alloy

Mechanical lifespan: ≥500 insertions and extractions

Impact: 3ms half-sine wave, acceleration peak 300g

Vibration: Sine wave vibration, 60g. Includes temperature cycling and simulation accessories (36 hours). Random vibration: 44.1g at high temperature.

Contact force at ambient temperature:

49.5 grams (minimum force in Newton)

22D#:45N

20#:67N

16#:111N

12#:111N

10#:111N

8#:111N

MIL-DTL-38999 Series III Connectors

IV. Preventing Incorrect Key Pressing

Front view of socket

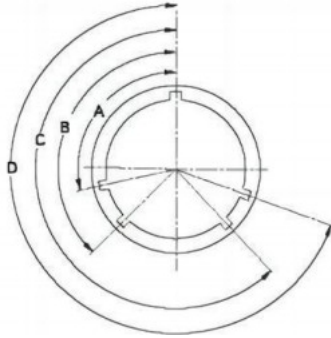

Front view of the plug

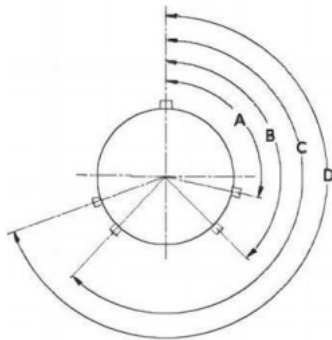

Shell number	MS complete number	Angle	N	A	B	C	D	E
9	A	A	105	102	80	35	64	91
		B'	140	132	118	140	155	131
		C'	215	248	230	205	234	197
		D°	265	320	312	275	304	240
11	B	A'	95	113	90	53	119	51
		B'	141	156	145	156	146	141
		C'	208	182	195	220	176	184
		D°	236	282	252	255	298	242
13	C	A°	95	113	90	53	119	51
		B''	141	156	145	156	146	141
		C'	208	182	195	220	176	184
		D°	236	292	252	255	298	242
15	D	A°	95	113	90	53	119	79
		B''	141	156	145	156	146	153
		C'	208	182	195	220	176	197
		CD°	236	292	252	255	298	272
17	E	A	B0	135	49	66	62	79
		B''	142	170	169	140	145	153
		C''	196	200	200	200	180	197
		D•	293	310	244	257	280	272
19	F	A°	80	135	49	66	62	79
		B''	142	170	169	140	145	153
		C''	196	200	200	200	180	197
		D'	293	310	244	257	280	272
21	G	A°	80	135	49	66	62	79
		B°	142	170	169	140	145	153
		:	196	200	200	200	1B0	197
			293	310	244	257	280	272
23	H	A°	80	135	49	66	62	79
		B''	142	170	169	140	145	153
		C'	196	200	200	200	180	197
		D'	293	310	244	257	280	272
25	J	A	80	135	49	66	62	79
		B°	142	170	169	140	145	153
		C'	196	200	200	200	180	197
		D°	293	310	244	257	2B0	272

V. Dimensions

1. Plug

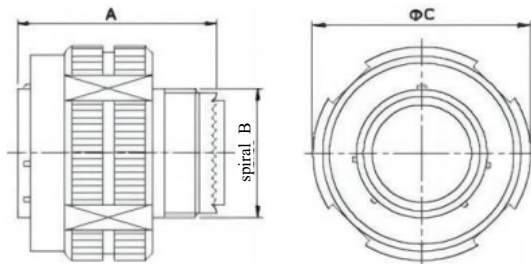

Complete Body Number	MS Shell ID	A maximum	B screw thread	C maximum
9	A	31.00	M 12×1-Bg	21.80
11	B	31.00	M 15×1-Bg	25.00
13	C	31.00	M 18×1-6g	29.40
15	D	31.00	M 22×1-6g	32.40
17	E	31.00	M 25×1-6g	35.60
19	F	31.00	M 28×1-6g	38.50
21	G	31.00	M 31×1-6g	41.70
23	H	31.00	M 34×1-Bg	44.90
25	J	31.00	M 37×1-Bg	48.00

MIL-DTL-38999 Series III Connectors

2. Square Plate Socket

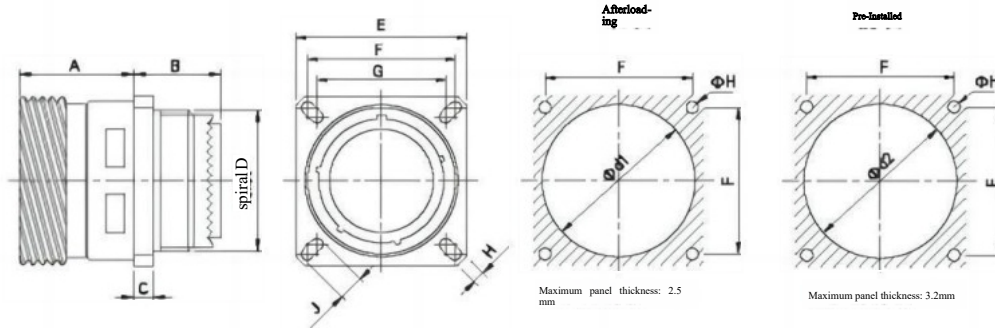

Shell number	MS Shell number	A maximum	B maximum	C maximum	D screw thread	E	F	G	H	J	d1 Minimum	d2 Minimum
9	A	20.90	10.60	2.50	M 12×1-6g	23.80	18.26	15.09	3.25	5.49	16.66	13.11
11	B	20.90	10.60	2.50	M 15×1-6g	26.20	20.62	18.26	3.25	4.93	20.22	15.88
13	C	20.90	10.60	2.50	M 18×1-6g	28.60	23.01	20.62	3.25	4.93	23.42	19.05
15	D	20.90	10.60	2.50	M 22×1-6g	31.00	24.61	23.01	3.25	4.39	26.59	23.01
17	E	20.90	10.60	2.50	M 25×1-6g	33.30	26.97	24.61	3.25	4.93	30.96	25.81
19	F	20.90	10.60	2.50	M 28×1-6g	36.50	29.36	26.97	3.25	4.93	32.94	28.98
21	G	20.10	11.40	3.20	M 31×1-6g	39.70	31.75	29.36	3.25	4.93	36.12	32.16
23	H	20.10	11.40	3.20	M 34×1-Bg	42.90	34.93	31.75	3.91	6.15	39.29	34.93
25	J	20.10	11.40	3.20	M 37×1-6g	46.00	38.10	34.93	3.91	6.15	42.47	37.69

3. Nut Fastener Socket

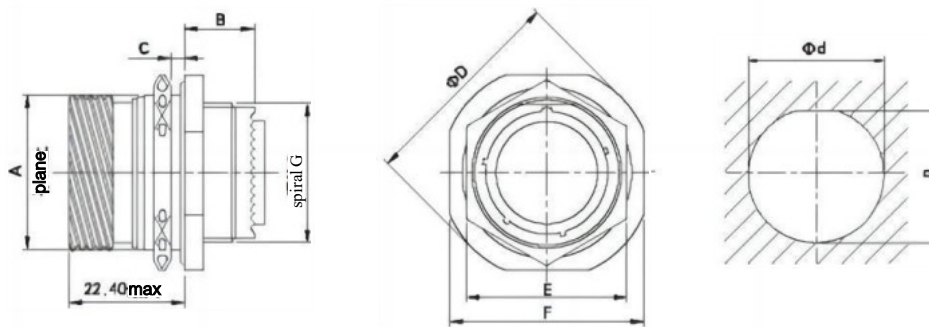

Shell number	MS Shell ID	A	B maximum	C maximum	D maximum	E maximum	F	G screw thread	d	P
9	A	16.50	9.90	3.20	30.50	24.00	27.00	M 12×1-6g	17.70	16.99
11	B	19.30	9.90	3.20	35.20	27.00	31.80	M 15×1-6g	20.88	19.53
13	C	24.00	9.90	3.20	38.40	32.00	34.90	M 18×1-6g	25.58	24.26
15	D	27.20	9.90	3.20	41.80	36.00	38.10	M 22×1-6g	28.80	27.53
17	E	30.40	9.90	3.20	44.80	37.00	41.30	M 25×1-6g	31.98	30.68
19	F	33.40	9.90	3.20	49.30	41.00	46.00	M 28×1-6g	35.15	33.86
21	G	36.50	9.90	3.20	52.70	46.00	49.20	M 31×1-8g	38.28	37.06
23	H	39.70	9.90	3.20	55.90	50.00	52.40	M 34×1-8g	41.50	40.24
25	J	42.80	9.90	3.20	59.00	51.23	55.60	M 37×1-6g	44.68	43.41

MIL-DTL-38999 Series III Connectors

4、Socket With Printed Circuit Board Contact

J599/24 socket

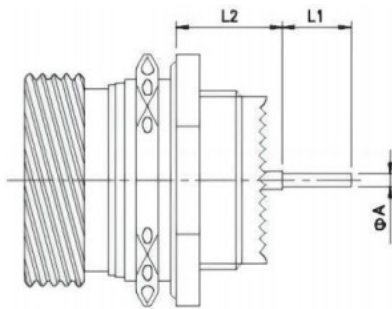

J599/20 socket

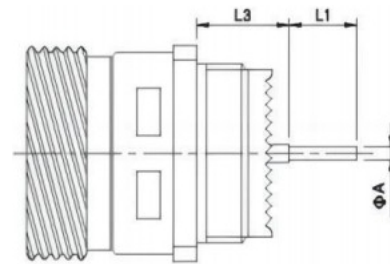

PCB contact specifications		L1	A
22D#	Long printed circuit board contact	8.5	0.7
	Short board contact	4.0	
20#	Long printed circuit board contact	8.5	0.7
	Short board contact	5.1	
16#	Long printed circuit board contact	8.5	1.15
	Short board contact	5.1	

Dimensions for installing contact pieces of different specifications			Shell Number 09-11	Shell numbers: 13-15-17-19-21-23-25
L2	When installing the 22D# pin	Minimum	10.52	10.34
		Maximum	11.46	11.28
	When installing the 22D# socket	Minimum	10.19	10.01
		Maximum	11.46	11.28
	When installing 20# or 18# pins and sockets	Minimum	10.69	10.51
		Maximum	11.63	11.45
L3	When installing the 22D# pin	Minimum	9.48	9.48
		Maximum	10.58	10.58
	When installing the 22D# socket	Minimum	9.15	9.15
		Maximum	10.58	10.58
	When installing 20# or 16# pins and sockets	Minimum	9.66	9.65
		Maximum	10.75	10.75

MIL-DTL-38999 Series III Composite Connectors

This series of round electrical connectors complies with GJB 599A (ML-DTL-38999K) Series III standards, featuring three-thread quick-connect technology with anti-loosening mechanisms. The compact design delivers lightweight construction, high contact density, electromagnetic shielding, detachable crimped contacts, and anti-slip pin insertion. The composite material housing with high-temperature resistant coating ensures robust vibration performance, making it ideal for harsh environments like sandstorms and humidity. Compared to aluminum housings, it weighs 30% less.

Product Logo Code

HL J599/ 20 W B 35 P N
 1 2 3 4 5 6 7 8

1 1. Taizhou Hanglong Electronics Co., Ltd. Corporate Name

2 — Basic serial number

3 — Shell type: 20 — Square socket
 24 — Nut-tightened socket
 26 — RFI shielded plug

4 — cladding material : J cadmium plating
 military green
 M-chemical plating nickel

5 — Shell body number: 09 11 13 15 17 19 21 23 25
 reference number A B C D E F G H J

6 1. Contact arrangement: See the contact arrangement diagram for details.

7 P-crimped pin (500 insertion/withdrawal cycles) PH-soldered pin PC-short PCB pin PL-long PCB pin H-crimped pin (1500 insertion/withdrawal cycles) H-soldered pin HC-short PCB pin HL-long PCB pin S-crimped hole (500 insertion/withdrawal cycles) SH-soldered hole SC-short PCB hole SL-long PCB hole J-crimped hole (1500 insertion/withdrawal cycles) H-soldered hole JC-short PCB hole JL-long PCB hole

CD: Outer part is a pin, inner part is a hole, with the flange located outside the compartment (wall-penetrating seat). DC: Outer part is a hole, inner part is a pin, with the flange located outside the compartment (wall-penetrating seat). A: Special pin contact component. B: Special socket contact component.

8 N-normal bond positions A, B, C, D, E-variable bond positions



pour :

- 1、 The National Standard GJB599A and the U.S. Military Standard ML-DTL-38999K share identical model designations except for their primary designations. GJB599A is designated as "J599", while MIL-DTL-38999K is designated as "D38999". These two standards are interchangeable.
- 2、 Identification codes A and B denote electrical connectors utilizing contact components (e.g., shielded, coaxial, or fiber optic types) that differ from the non-standard GJB1611 configuration. These components require separate ordering. For specific model specifications, refer to "Special Contact Components for GJB599III Series".
- 3、 The compatible sealing caps, tail attachments, and square disc rubber pads for this product series are detailed in pages P71-P84.

MIL-DTL-38999 Series III Composite Connectors

Product Technical Characteristics

I. Environmental Conditions for Use

Salt fog: 2000 hours

Temperature range: Class J 65°C~+175°C

Class M-65°C~+200°C

Seal: The plug-in connector complies with the MIL-DTL-38999K low-pressure immersion test requirements.

Wet heat: per MIL-DTL-38999K:10 cycles in 24 hours

Fuel-resistant: Resistant to various fuels, coolants, and solvents

II. Electrical Characteristics

Voltage rating: (Vms)

Going	Sea level	At an altitude of 21,000 meters
M	1300	B00
N	1000	600
I	1800	1000
II	2300	1000

Insulation resistance: greater than or equal to 5000 MΩ at 500Vdc

Conductivity of shell: Class J: 3mΩ Class M:3mΩ

Shielding performance: 90dB at 100GHz and 85dB at 1GHz

Note: Different contact arrangements have different operating conditions. See "Contact Arrangement" for details.

Contact resistance and rated current of contact

Contact specifications	Working diameter mm	Contact resistance mΩ	Rated current A
22D	①0.76	≤12	5
20#	①1.00	≤5	7.5
16#	①1.60	≤2.5	13
12"	①2.40	≤1.5	23
10#	①3.15	≤1.0	40

III. Mechanical Properties

Shell: Composite

Coating: J-cadmium-plated
military green M-
nickel-plated

Insulator: thermoplastic or thermosetting material

Sealing body and sealing ring: silicone rubber

Contact: Gold-plated copper alloy

Mechanical lifespan: ≥1500 insertions and extractions

Impact: 3ms half-sine wave, acceleration peak 300g

Vibration: Sine vibration: 60g. Includes temperature cycling and simulation accessories (36 hours). Random vibration: 44.1g at high temperature.

Contact force at ambient temperature: 49.5 grams (minimum force in Newton)

22D#:45N

20#:67N

16#:111N

12#:111N

10#:111N

8#:111N

MIL-DTL-38999 Series III Composite Connectors

IV. Contact Arrangement (View of Needle Insulator Insertion Surface)



D9-35 M

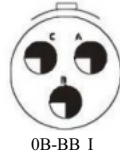

0B-BB I



11-35 M



11-98 I

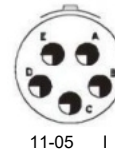

11-05 I

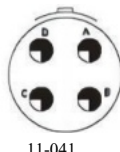

11-041



11-01 I

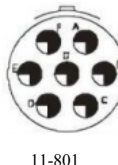

11-801



13-35 M



13-12



13-98 I

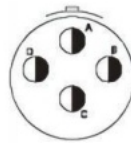

13-04 I

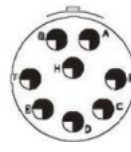

13-08 I

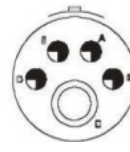

13-50 M

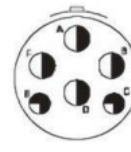

13-80 I



15-35 M

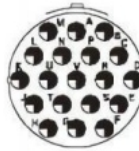

15-19 I



15-18 I

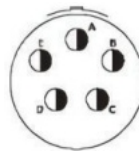

15-05 II



15-971



15-15 I

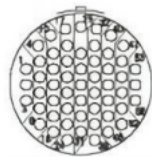

17-35 M

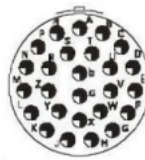

17-281

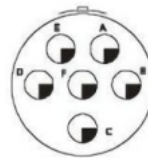

17-08 I

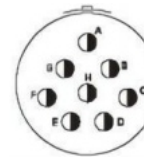

17-08II

MIL-DTL-38999 Series III Composite Connectors

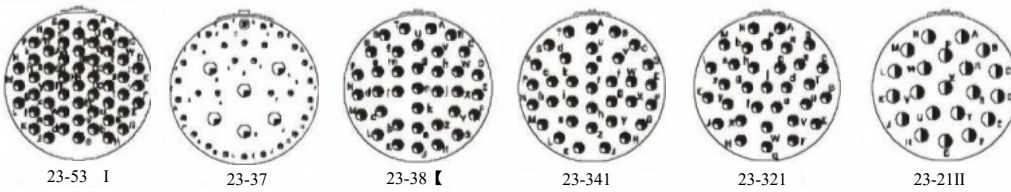
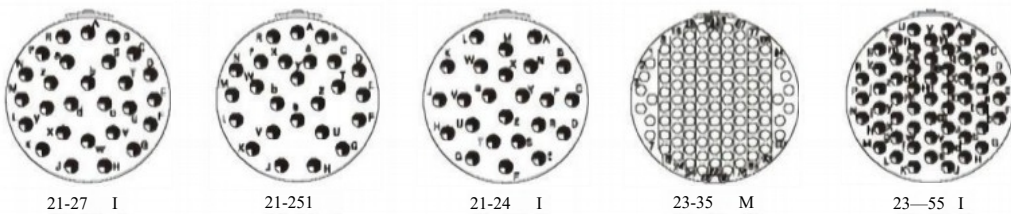
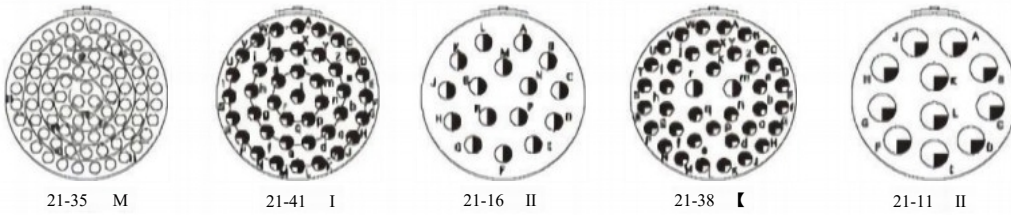
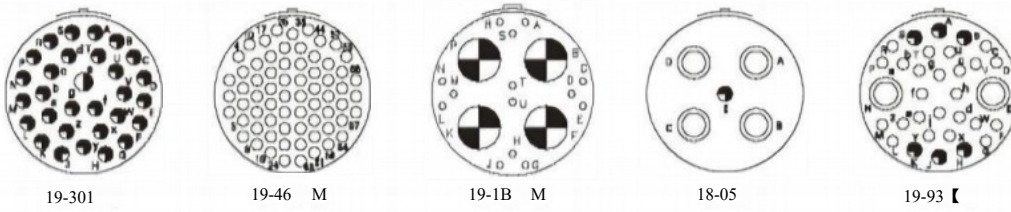
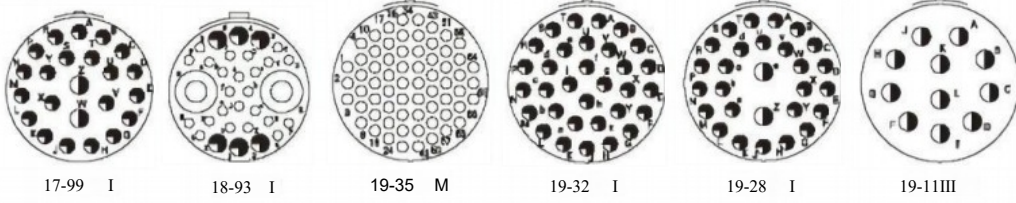

MIL-DTL-38999 Series III Composite Connectors

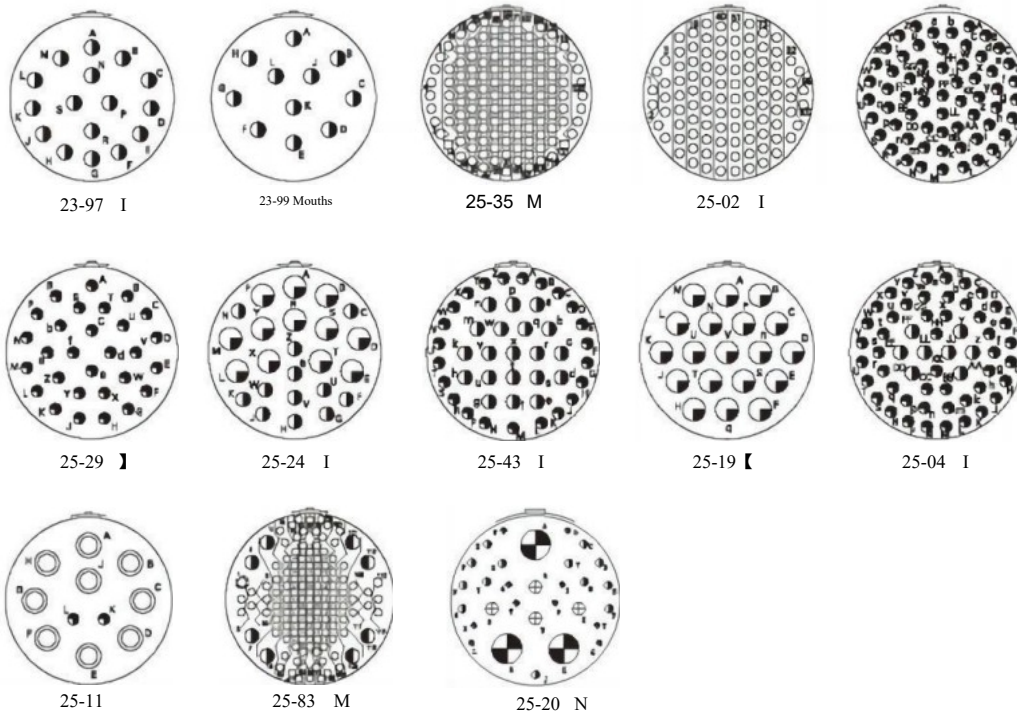

Note: Contact piece diameter marked as 022D# 20# coaxial \circ 1 6 #

8 # Dual coaxial

V. Dimensions

1. Plug

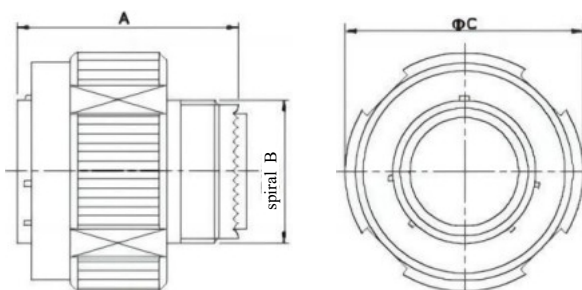

Shell number	MS optical number	A maximum	B screw thread	C maximum
9	A	31.00	M 12×1-6g	21.80
11	B	31.00	M 15×1-6g	25.00
13	C	31.00	M 18×1-6g	29.40
15	D	31.00	M 22×1-6g	32.40
17	E	31.00	M 25×1-6g	35.60
19	F	31.00	M 28×1-6g	38.50
21	G	31.00	M 31×1-6g	41.70
23	H	31.00	M 34×1-6g	44.90
25	J	31.00	M 37×1-6g	48.00

MIL-DTL-38999 Series III Composite Connectors

2、 Square Plate Socket

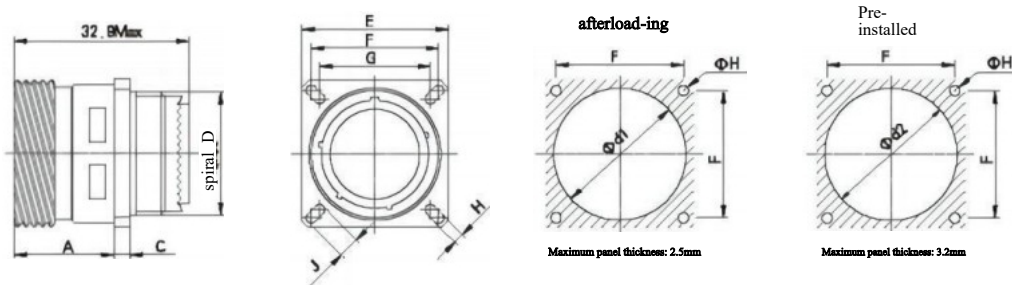

Shell number	MS Shell ID	A maximum	c maximum	D screw thread	E	F	G	H	J	d1 minimum	d2 minimum
9	A	19.8	3.65	M 12×1-6g	23.80	18.26	15.09	3.25	5.49	16.66	13.11
11	B	19.8	3.65	M 15×1-6g	26.20	20.62	18.26	3.25	4.93	20.22	15.88
13	C	19.8	3.65	M 18×1-6g	28.60	23.01	20.62	3.25	4.93	23.42	19.05
16	D	19.8	3.66	M 22×1-6g	31.00	24.61	23.01	3.25	4.39	26.59	23.01
17	E	19.8	3.65	M 25×1-6g	33.30	26.97	24.61	3.25	4.93	30.96	25.81
19	F	19.8	3.65	M 28×1-6g	36.50	29.36	26.97	3.25	4.93	32.94	28.98
21	G	19.0	4.35	M 31×1-8g	39.70	31.75	29.36	3.25	4.93	36.12	32.16
23	H	19.0	4.35	M 34×1-6g	42.90	34.93	31.75	3.91	6.15	39.29	34.93
25	J	19.0	4.35	M 37×1-6g	46.00	38.10	34.93	3.91	6.15	42.47	37.69

3、 Nut Fastener Socket

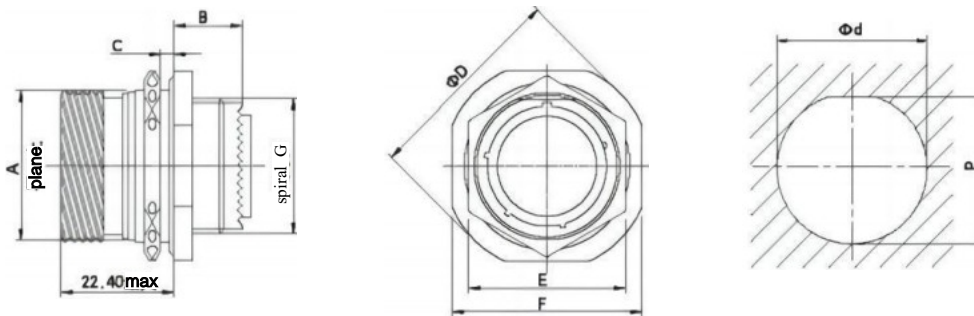

Shell number	MS Shell ID	A	B maximum	C maximum	D maximum	E maximum	F	G screw thread	d	P
9	A	16.50	9.90	3.20	30.50	24.00	27.00	M 12×1-Bg	17.70	16.99
11	B	19.30	9.90	3.20	35.20	27.00	31.80	M 15×1-Bg	20.88	19.53
13	C	24.00	9.90	3.20	38.40	32.00	34.90	M 18×1-6g	25.68	24.26
15	D	27.20	9.90	3.20	41.60	36.00	38.10	M 22×1-6g	28.80	27.53
17	E	30.40	9.90	3.20	44.80	37.00	41.30	M 25×1-Bg	31.98	30.68
19	F	33.40	9.90	3.20	49.30	41.00	46.00	M 28×1-Bg	35.15	33.86
21	G	36.50	9.90	3.20	52.70	46.00	49.20	M 31×1-6g	38.28	37.06
23	H	39.70	9.90	3.20	55.90	50.00	52.40	M 34×1-6g	41.50	40.24
25	J	42.80	9.90	3.20	59.00	51.23	55.60	M 37×1-6g	44.68	43.41

MIL-DTL-38999 Series III Composite Connectors

4、 Socket With Printed Circuit Board Contact

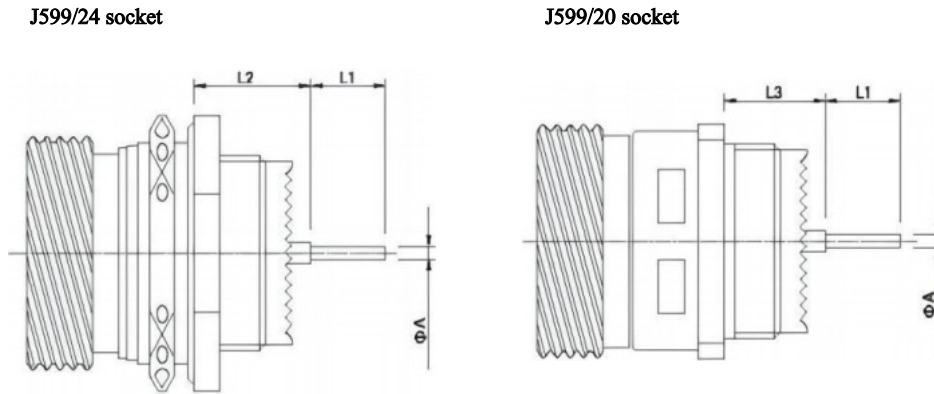

PCB contact specifications		L1	A
22D#	Long printed circuit board contact	8.5	0.7
	Short board contact	4.0	
20#	Long printed circuit board contact	8.5	0.7
	Short board contact	5.1	
16#	Long printed circuit board contact	8.5	1.15
	Short board contact	5.1	

Dimensions for installing contact pieces of different specifications			Shell Number 09-11	Shell numbers: 13-15-17-19-21-23-25
L2	When installing the 22# pin	Minimum	10.52	10.34
		Maximum	11.46	11.28
	When installing the 22# socket	Minimum	10.19	10.01
		Maximum	11.46	11.28
	When installing 20# or 16# pins and sockets	Minimum	10.69	10.51
		Maximum	11.63	11.45
L3	When installing the 22# pin	Minimum	9.48	9.48
		Maximum	10.58	10.58
	When installing the 22# socket	Minimum	9.15	9.15
		Maximum	10.58	10.58
	When installing 20# or 16# pins and sockets	Minimum	9.65	9.65
		Maximum	10.75	10.75

MIL-DTL-38999 Series III Composite Connectors

VI. Dimensions of Plug and Socket After Connection

Square plate socket (J599/20)/plug (J599/26)

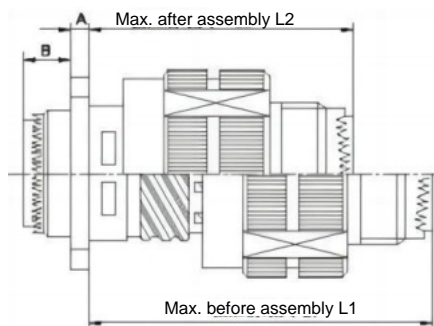

Nut fastener socket (J599/24)/plug (J599/26)

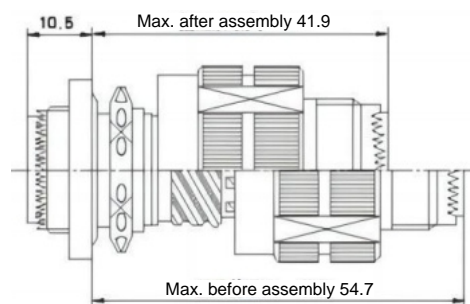

Shell number		09	11	13	15	17	19	21	23	25
L1	MAX	53.2	53.2	53.2	53.2	53.2	53.2	52.4	52.4	52.4
L2	MAX	40.3	40.3	40.3	40.3	40.3	40.3	39.6	39.6	39.6
A	MAX	2.5	2.5	2.5	2.5	2.5	2.5	3.2	3.2	3.2
B	MAX	9.6	9.6	9.6	9.6	9.6	9.6	9.6	9.6	9.6

7. Product Marking Code for

Plug and Socket Sealing Covers

HL J599/32 F 09 N
 1 2 3 4 5

1—Qinzhou Hanglong Electronics Co., Ltd. Corporate Name

2— Basic component number:

J599/32-Plug seal cover (corresponding to US military standard component number D38999/32)

J599/33-Socket seal cover (corresponding to US military standard component number D38999/33)

3 1. Surface coating: W-Cadmium-plated military green F-Chemical nickel-plated J-Cadmium-plated military green (composite material)

K-Stainless steel passivation M-Chemical nickel plating (composite material) 4-Shell numbers: 09,11,13,15,17,19,21,23,25

5— Chain type: N-Stainless steel cable loop R-Stainless steel cable eye

Note: The sealing cap must be ordered separately and is not included with the connector.

MIL-DTL-38999 Series III Composite Connectors

outline dimension

plug seal cover
J599/32 (D38999/32)

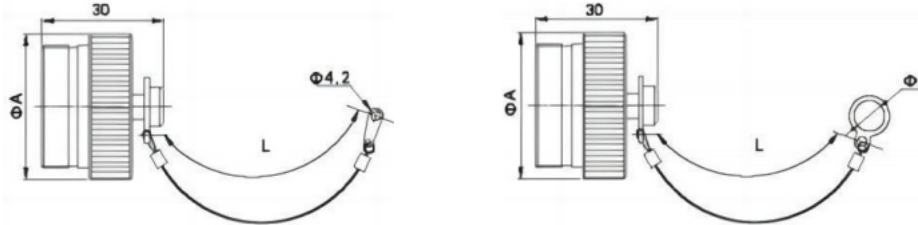

Sealing cap for socket
J599/33 (D38999/33)

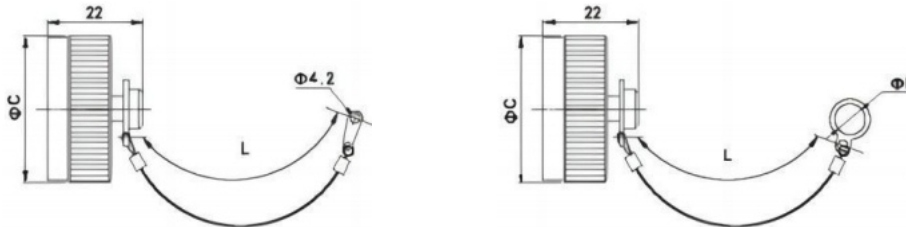

Shell number		09	11	13	15	17	19	21	23	25
A	MAX	22.86	25.40	30.48	33.02	36.83	39.37	43.18	44.45	48.26
B	MIN	12.82	17.78	19.27	22.60	25.62	28.95	31.97	34.03	38.32
C	MAX	22.86	27.86	30.48	31.75	36.83	38.10	41.91	44.45	48.26
D	MIN	17.78	21.33	25.62	28.95	31.97	35.30	38.32	41.65	44.45
L	MAX	148	148	148	169	169	200	200	20D	200

Standard Tail Attachment

Product logo code

HL J1784A/ 38- 15 N A
1 2 3 4 5 6

1. Taizhou Hanglong Electronics Co., Ltd. – Corporate Name

2— Basic component number

3—Detailed specification number: 14-tail nut 16. One-bend cable clamp 18. Straight-shielded cable clamp

20-Shielded Tail Attachment 3B Straight Cable Clamp 39-Bend Cable Clamp

69—Heat-shrinkable sheathed tail attachment 01-Grounded compression type 06-spring wire guard type

4—Case numbers: 09,11,13,15,17,19,21,23,25

5 1. Shell coating: W-coated cadmium military green N-chemically plated nickel A-black anodized

S-stainless steel passivated 6-A indicates non-standard length

MIL-DTL-38999 Series III Composite Connectors

J1784A/14-tail nut

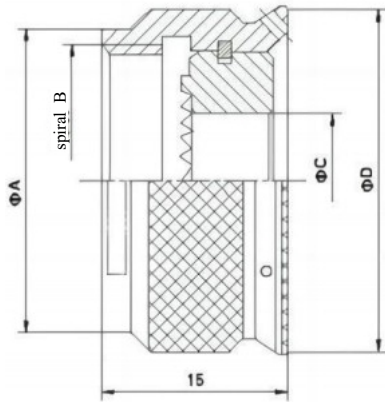

Shell number	A	Screw thread B	C	D
09	15.2	M12×1	6.7	19.0
11	18.2	M15×1	9.9	21.6
13	21.2	M18×1	12.8	25.4
15	25.1	M22×1	16.0	28.0
17	28.1	M25×1	19.2	31.8
19	31.1	M28×1	21.4	35.6
21	34.0	M31×1	24.6	38.0
23	37.0	M34×1	27.7	40.0
25	40.0	M37×1	30.9	44.5

J1784A/20-Shielded Tail Attachment

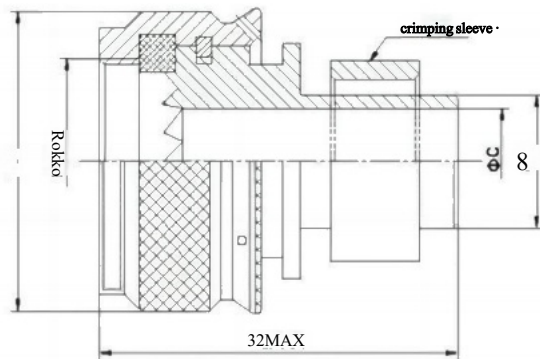

◆ The crimping sleeve must be crimped using the dedicated crimping tool YTQ, which requires separate purchase.

Shell number	A	Screw thread B	C	D	Select pressure Block mark
09	19.0	M12×1	6.55	8.81	0B
11	21.6	M15×1	8.83	12.65	10
13	25.4	M18×1	10.90	12.95	12
15	28.0	M22×1	14.10	16.00	14
17	31.8	M25×1	17.25	19.30	16
19	35.6	M28×1	20.40	22.61	18
21	38.0	M31×1	23.60	25.65	20
23	40.0	M34×1	26.40	28.70	22
25	44.5	M37×1	28.40	30.53	24

J1784A/69-Heat-shrinkable sheathed tail attachment

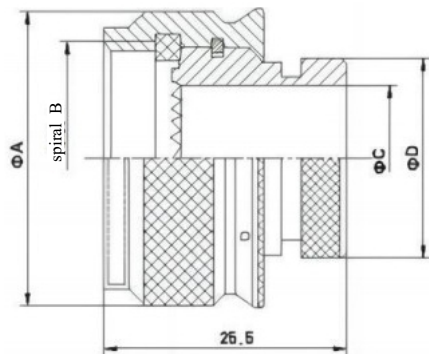

Shell number	A	Screw thread B	C	D
09	19.0	M12×1	6.7	13.5
11	21.6	M15×1	9.9	15.3
13	25.4	M18×1	12.8	19.6
15	28.0	M22×1	16.0	21.2
17	31.8	M25×1	19.2	24.4
19	35.6	M28×1	21.4	26.4
21	38.0	M31×1	24.6	30.9
23	40.0	M34×1	27.7	34.4
25	44.5	M37×1	30.9	36.6

MIL-DTL-38999 Series III Composite Connectors

J1784A/38 Continuous Cable Clamp

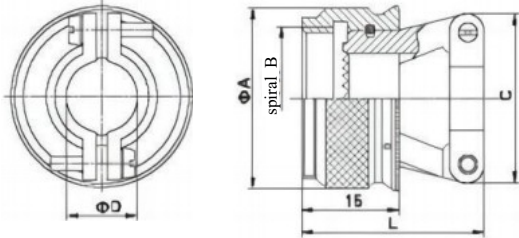

Shell number	A maximum	Screw thread B	C Maximum	D Minimum	D Maximum	L Maximum
09	19.0	M12×1	20.0	2.49	5.94	27.0
11	21.6	M15×1	21.0	3.87	5.94	28.5
13	25.4	M18×1	23.4	4.83	8.33	30.0
15	28.0	M22×1	26.6	6.60	11.61	31.5
17	31.5	M25×1	30.6	7.19	15.80	33.5
19	35.6	M28×1	34.0	8.26	16.10	36.6
21	38.0	M31×1	35.8	8.71	17.73	39.8
23	40.0	M34×1	39.0	9.68	20.90	42.9
25	44.5	M37×1	40.6	10.62	21.66	45.0

J1784A/39 – A curved cable clamp

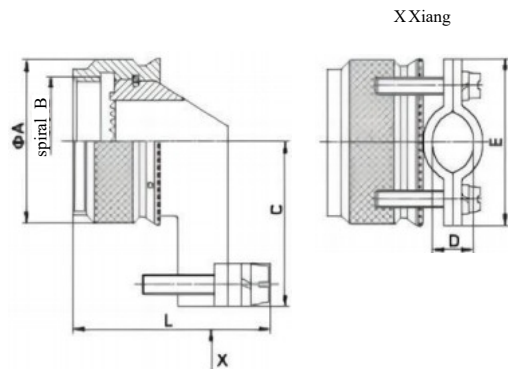

Shell number	A maximum	Screw thread B	C maximum	D		E maximum	L maximum
				Minimum	Maximum		
09	19.0	M12×1	20.80	2.49	5.94	21.6	29.5
11	21.6	M15×1	22.00	3.87	5.94	22.8	29.5
13	25.4	M18×1	23.60	4.83	8.33	26.0	31.9
15	28.0	M22×1	25.20	6.60	11.61	29.0	35.1
17	31.8	M25×1	26.80	7.19	15.61	30.6	39.1
19	35.6	M28×1	31.30	8.26	16.10	37.0	41.5
21	38.0	M31×1	32.90	8.71	17.73	39.0	43.3
23	40.0	M34×1	34.50	9.68	20.90	41.0	46.5
25	44.5	M37×1	36.10	10.62	21.66	42.0	47.1

J1784A/16 – A curved cable clamp

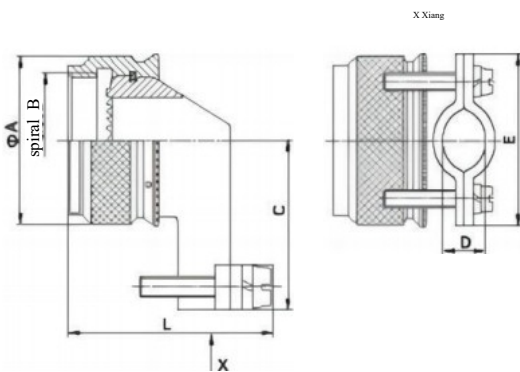

Shell number	A maximum	Screw thread B	C maximum	D		E maximum	L maximum
				Minimum	Maximum		
09	19.0	M12×1	20.0	2.85	6.71	21	25.9
11	21.6	M15×1	21.5	6	8.86	26.5	29.2
13	25.4	M18×1	23.0	8.45	12.85	31.5	32
15	28.0	M22×1	25.0	12	16.03	36.5	35.2
17	31.5	M25×1	27.0	11.1	19.2	31	36.4
19	35.6	M28×1	28.5	13.75	21.46	37	40.7
21	38.0	M31×1	29.5	19.3	24.64	35	43.8
23	40.0	M34×1	31.0	21.4	27.81	35	43
25	44.5	M37×1	33.0	23.5	30.99	37	44.2

MIL-DTL-38999 Series III Composite Connectors

J1784A/01-Grounding and Tensioning Tail Attachment

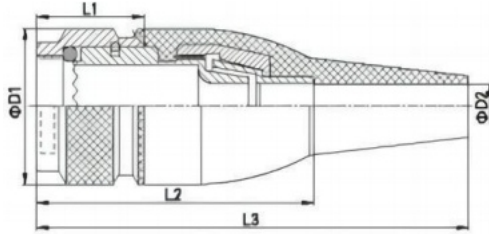

Model	D1	D2	L1	L2	L3
J17B4A/01-09N	19.0	7.0	14.8	37.0	53.0
J1784A/01-11N	21.6	10.0	14.8	37.0	53.0
J1784A/01-13N	25.4	13.0	14.8	37.0	53.0
J1784A/01-15N	28.0	15.0	14.8	40.0	73.0
J1784A/01-17N	31.8	18.0	14.8	40.0	73.0
J1784A/01-19N	36.6	20.0	14.8	40.0	73.0
J1784A/01-21N	38.0	23.5	14.8	45.0	73.0
J1784A/01-23N	40.0	26.5	14.8	46.0	73.0
J1784A/01-25N	44.5	29.0	14.8	46.0	73.0

J1784A/06-Wire Guard Spring Tail Attachment

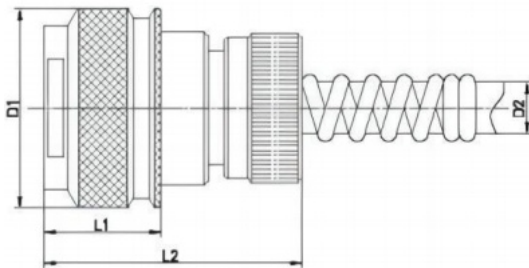

Model	D1	D2	L1	L2
J1784A/06-09N	19.0	7.0	14.8	37.0
J1784A/06-11N	21.6	10.0	14.8	37.0
J1784A/06-12N	25.4	13.0	14.8	37.0
J1784A/06-13N	28.0	15.0	14.8	40.0
J1784A/06-15N	31.8	18.0	14.8	40.0
J1784A/06-17N	35.6	20.0	14.8	40.0
J1784A/06-21N	38.0	23.5	14.8	45.0
J17B4A/06-23N	40.0	26.5	14.8	45.0
J1784A/0B-25N	44.5	29.0	14.8	45.0

Product Logo Code

J1784A/18-xxN

$\frac{HL}{1}$ $\frac{J1784A/}{2}$ $\frac{18-}{3}$ $\frac{25}{4}$ $\frac{N}{5}$ $\frac{09}{6}$ $\frac{A}{7}$

1—Taizhou Hanglong Electronics Co., Ltd. Corporate Name

2— Basic component number: J1784A

3 — Detailed specification number: 18 — Straight shielded cable clamp

4— Shell number: see Table 1

5— Shell coating: N—electroless nickel plating W—military green plating S—stainless steel passivation

6—Line diameter code: see Table 2

7—Length encoding: see Table 3

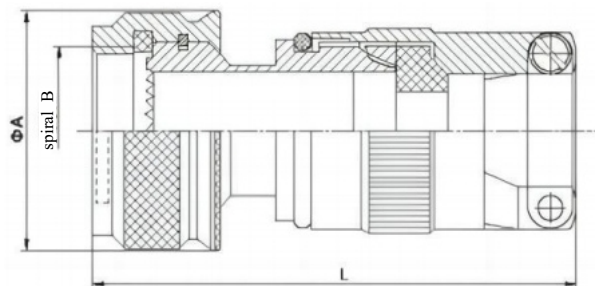
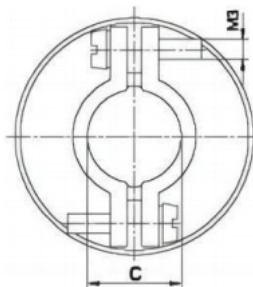

MIL-DTL-38999 Series III Composite Connectors

Table 1

Photonic Number	Select wire diameter code	A	Screw thread B
9	01~02	19.0	M12×1
11	01~03	21.6	M15×1
13	02~04	25.4	M ¹ 0 × 1
15	02~05	28.0	M22×1
17	02~06	31.8	M25×1
10	03~07	35.6	M2B×1
21	03~08	38.0	M31×1
23	03~09	40.0	M34×1
25	04~10	44.5	M37×1

Table 2

Outlet diameter number	Dimension range (C)
01	1.57~3.18
02	3.18~6.35
3	6.35~9.53
4	9.53~12.7
5	12.7~15.88
6	15.88~19.05
7	19.05~22.23
8	22.23~25.4
9	26.4~28.58
10	28.58~31.75

Table 3

Photonic Number	RLE	L
9~25	Standard (not shown)	64.4
9~25	A	89.8
15~25	B	115.2
21~25	C	140.6

J1784A/38-xx NB

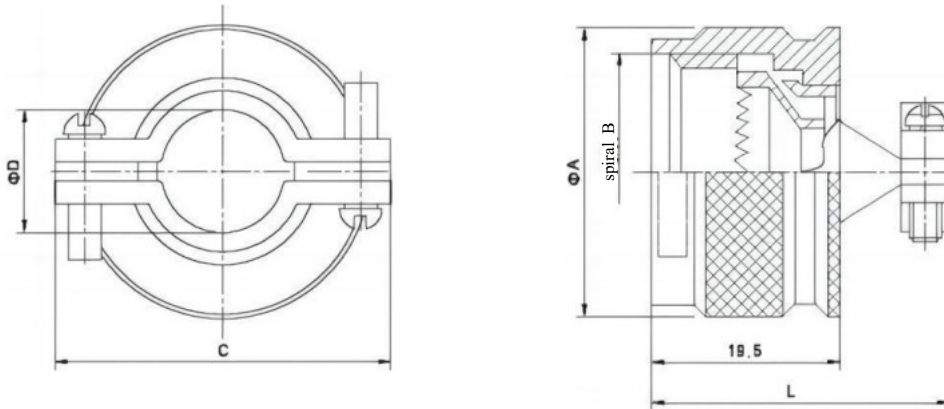

Attachment type	A	Screw thread B	C	D minimum	D maximum	L
J1784A/38-9NB	19.0	M12×1	18.6	3.5	5.7	29.2
J1784A/38-11NB	21.6	M15×1	20.6	5.0	7.9	29.2
J1784A/38-13NB	25.4	M18×1	24.5	7.4	11.4	29.2
J1784A/38-15NB	28.0	M22×1	26.0	9.0	12.9	29.8
J1784A/38-17NB	31.8	M25×1	33.0	12.8	17.0	31.0
J1784A/38-19NB	36.6	M2B×1	36.3	13.2	17.9	32.0
J1784A/38-21NB	38.0	M31×1	39.0	14.4	21.1	32.0
J1784A/38-23NB	40.0	M34×1	41.4	16.4	24.3	32.0
J1784A/38-25NB	44.5	M37×1	44.5	18.0	27.5	32.0

MIL-DTL-38999 Series III Composite Connectors

Tail Attachment of Composite

Product logo code

$\frac{HL}{1}$ $\frac{J1784A/}{2}$ $\frac{91-}{3}$ $\frac{15}{4}$ $\frac{J}{5}$

1—Taizhou Hanglong Electronics Co., Ltd. Corporate Name

2 1 Basic Element Number

3. Detailed specification number: 20. Shielded tail accessory: 91. Straight cable clamp: 92. Curved cable clamp:

4—Case numbers: 09,11,13,15,17,19,21,23,25

5 — Shell coating: J one electroless cadmium plating military green M one electroless nickel plating

J1784A/20-xxJ (Composite Material)

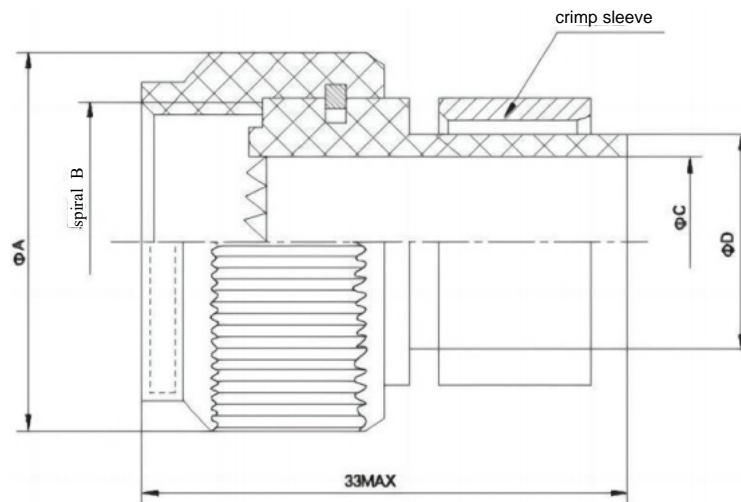

Attachment type	A	Screw thread B	C	D
J1784A/20-9J	21.8	M12×1	6.73	12.65
J' 784A/20-11J	25	M15×1	8.71	12.95
J1784A/20-13J	29.5	M18×1	11.1	16
J1784A/20-15J	32.5	M22×1	14.27	18.3
J1784A/20-17J	35.5	M25×1	17.46	22.61
J17B4A/20-19J	38.5	M2B×1	20.62	25.65
J1784A/20-21J	41.5	M31×1	23. B	28.7
J1784A/20-23J	45	M34×1	26.57	30.53
J1784A/20-25J	48	M37×1	28.5B	34.52

MIL-DTL-38999 Series III Composite Connectors

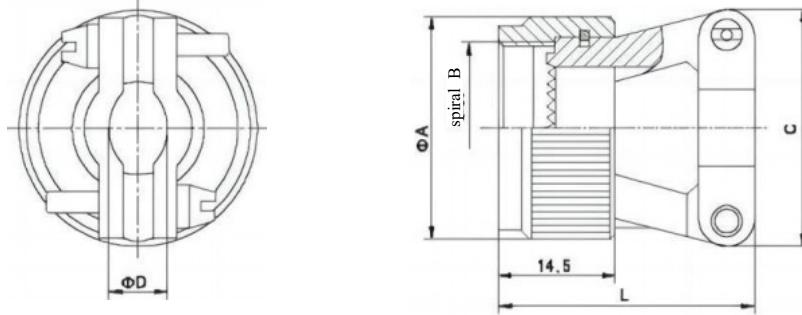

Shell number	A maximum	Thread Day	C maximum	D minimum	D maximum	L maximum
09	21.8	M12×1	20.0	4.00	5.94	27.0
11	25	M15×1	20.0	4.00	5.94	28.5
13	29.5	M' B×1	23.4	4.83	8.33	30.0
15	32.5	M22×1	26.6	6.60	11.61	31.5
17	35.5	M25×1	30.6	7.19	15.60	33.5
19	38.5	M28×1	34.0	8.26	16.10	36.6
21	41.5	M31×1	35.8	8.71	17.73	39.8
23	45	M34×1	39.0	9.68	20.90	42.9
25	48	M37×1	40.6	10.62	21.66	45.0

J1784A/92-xxJ (Composite Material)

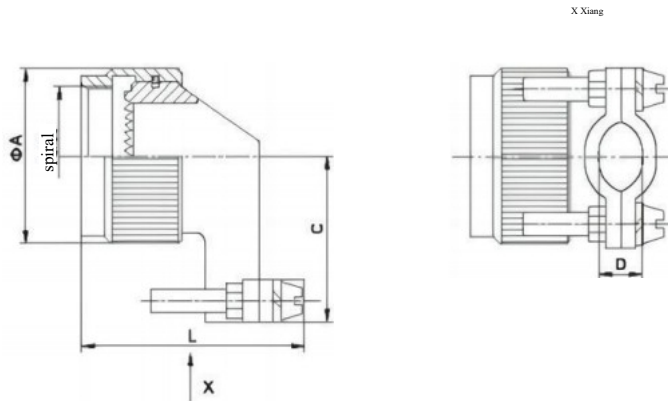

Shell number	A maximum	Screw thread B	C maximum	D minimum	D maximum	L maximum
09	21.8	M12×1	20.6	2.49	5.94	29.5
11	25	M15×1	22.0	3.87	5.94	29.5
13	29.5	M1B×1	23.6	4.83	8.33	31.0
15	32.5	M22×1	25.2	6.60	11.61	35.1
17	35.5	M25×1	26.8	7.19	15.60	39.1
19	38.5	M20×1	31.3	8.26	16.10	41.5
21	41.5	M31×1	32.9	8.71	17.73	43.3
23	45	M34×1	34.5	9.68	20.90	46.5
25	48	M37×1	36.1	10.62	21.66	47.1

MIL-DTL-38999 Series III Composite Connectors

Special Tail Attachment

This type of tail attachment is specifically designed for securing shielded cables with shielding nets, available in two main types: straight and curved. The attachment can be optionally equipped with Ti alloy memory.

The Ni alloy memory ring, when heated, contracts to tightly clamp the shielding mesh around the accessory's tail, achieving true 360° electromagnetic shielding.

● Thermal shrinkage of Ti-Ni alloy memory rings: The rings can be heated using either a dedicated resistance heater (which applies current through their inherent resistance) or a hot air gun. When the temperature indicator on the ring changes from green to black, indicating complete contraction, the temperature reaches approximately 165°C, and heating should be stopped. Ensure even heat distribution during the process. Electric heating requires about 4-5 seconds, while hot air gun heating takes 45 seconds to 1 minute.

Product Logo Code

HL JY599 III 15 FJA 00 F A -05
1 2 3 4 5 6 7 8 9

1— Taizhou Hanglong Electronics Co., Ltd. (Company Name)

2— Basic component number

3— Series code: III

4—Case numbers: 09,11,13,15,17,19,21,23,25

5 —Attachment type:FJA,FJB,FJC,FJE 6-Structure form: 00 straight
tail attachment 90-90° curved attachment

7-Shell body coating: W-cadmium-plated military green F-chemically nickel-plated

8— Titanium-nickel ring: Unmarked 1. No titanium-nickel ring A-Optional titanium-nickel ring (applicable only to FJA and FJC models)

9— Outlet diameter or titanium-nickel ring specifications

The diameter of the outlet is marked when there is no titanium-nickel ring.

Specify the titanium-nickel ring specifications when optional

outline dimension

Vertical attachment (D38999III—FJA00)

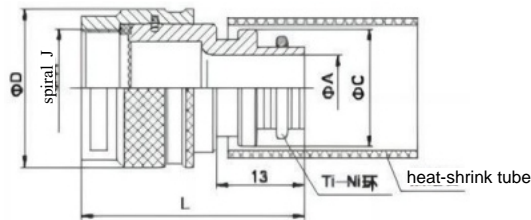

Bend-type attachment (D38999III—FJA90)

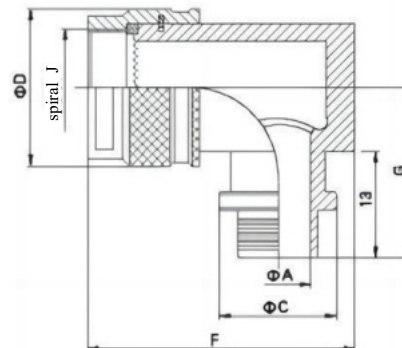

MIL-DTL-38999 Series III Composite Connectors

Order number	Shell sequence number	Ti-Ni ring specifications	Screening grid specification (nominal diameter of tin-plated copper wire)	A Outlet diameter		C		F	D	G	Screw thread J
				Vertical	Bent	Vertical	Bent				
1	09	TR-04	6×10(0.15~0.20)	6.3	6.3	14.0	14.0	38.2	19	26	M12×1-6H
		TH-05	10×16(0.15~0.20)	7.9	7.9	15.5	15.0				
		TH-06	10×16(0.15~0.20)	9.5		17.1	2				
2	11	TH-04	6×10(0.15~0.20)	6.3	6.3	14.0	14.0	39.7	21.6	26	M15×1-6H
		TH-05	10×16(0.15~0.20)	7.9	7.9	15.5	15.5				
		TH-06	10×16(0.15~0.20)	9.5	9.5	17.1	17.1				
		TH-07	10×16(0.12~0.20)	11.1	11.1	18.7	18.0				
3	13	TR-04	6×10(0.15~0.20)	6.3	6.3	14.0	14.0	45.2	25.4	29	M18×1-6H
		TH-05	10×16(0.15~0.20)	7.9	7.9	15.5	15.5				
		TH-06	10×16(0.15~0.20)	9.5	9.5	17.1	17.1				
		TH-07	10×16(0.12~0.20)	11.1	11.1	18.7	18.7				
		TR-08	16×24(0.12~0.25)	12.7	12.7	20.3	20.3				
4	15	TR-10	16×24(0.10~0.30)	16.0	16.0	23.5	23.0	47.0	2B	29	M22×1-6H
		TH-05	10×16(0.15~0.20)	7.9		15.5	2				
		TH-06	10×16(0.15~0.20)	9.5	9.5	17.1	17.1				
		TH-07	10×16(0.12~0.20)	11.1	11.1	18.7	18.7				
		TR-08	16×24(0.12~0.25)	12.7	12.7	20.3	20.3				
		TH-10	16×24(0.10~0.30)	16.0	16.0	23.5	23.5				
5	17	TH-12	16×24(0.10~0.30)	19.0	19.0	26.7	25.5	50.7	31.8	33	M25×1-6H
		TH-05	10×16(0.15~0.20)	7.9		15.5					
		TH-06	10×16(0.15~0.20)	9.5		17.1					
		TH-07	10×16(0.12~0.20)	11.1	11.1	18.7	18.7				
		TR-08	16×24(0.12~0.25)	12.7	12.7	20.3	20.3				
		TH-10	16×24(0.10~0.30)	16.0	16.0	23.5	23.5				
6	19	TH-14	24×30(0.10~0.30)	22.2		30.0	2	53.5	35.6	33	M2B×1-6H
		TH-08	16×24(0.12~0.25)	12.7	12.7	20.3	20.3				
		TR-10	16×24(0.10~0.30)	16.0	16.0	23.5	23.5				
		TH-12	16×24(0.10~0.30)	19.0	19.0	26.7	26.7				
		TH-14	24×30(0.10~0.30)	22.2	22.2	30.0	30.0				
7	21	TF-16	24×30(0.10~0.30)	25.4	25.4	33.0	32.0	55.7	3B	39	M31×1-6H
		TR-08	16×24(0.12~0.25)	12.7	12.7	20.3	20.3				
		TH-10	16×24(0.10~0.30)	16.0	16.0	23.5	23.5				
		TH-12	16×24(0.10~0.30)	19.0	19.0	26.7	26.7				
		TH-14	24×30(0.10~0.30)	22.2	22.2	30.0	30.0				
		TH-16	24×30(0.10~0.30)	25.4	25.4	33.0	33.0				
B	23	TH-18	30×40(0.10~0.30)	28.5		36.2		68.2	40	39	M34×1-6H
		TH-10	16×24(0.10~0.30)	16.0	16.0	23.5	23.5				
		TF-12	16×24(0.10~0.30)	19.0	19.0	26.7	26.7				
		TH-14	24×30(0.10~0.30)	22.2	22.2	30.0	30.0				
		TR-16	24×30(0.10~0.30)	25.4	25.4	33.0	33.0				
9	25	TH-18	30×40(0.10~0.30)	28.5	28.5	36.2	36.2	63.7	44.5	44	M37×1-6H
		TH-20	30×40(0.10~0.30)	31.8	31.8	39.4	39.4				
		TH-22	30×40(0.10~0.30)	35.0	35.0	42.5	42.0				
		TF-10	16×24(0.10~0.30)	2	16.0		23.5				
		TH-12	16×24(0.10~0.30)	19.0	19.0	26.7	26.7				
		TH-14	24×30(0.10~0.30)	22.2	22.2	30.0	30.0				
		TH-16	24×30(0.10~0.30)	25.4	25.4	33.0	33.0				

MIL-DTL-38999 Series III Composite Connectors

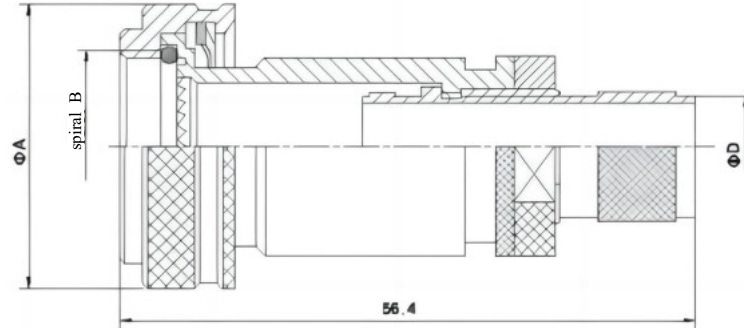

Attachment type	A	Thread Day	D
JY589III-11FJB00F	21.6	M15×1	6.5
JY599III-15FJB00F	28	M22×1	12.5
JY599III-17FJB00F	31. sun	M25×1	19.5
JY599III-21FJB00F	38	M31×1	25.5

D38999III-xxFJC00

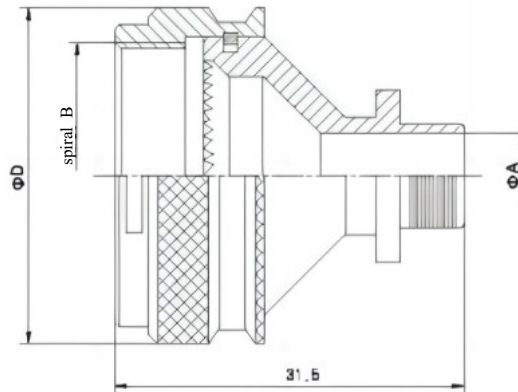

Shell number	A Outlet diameter	Thread Day	D	Adaptation of Ti- Ni Ring Model
11	7.9	M15×1	21.6	TR-05
13	9.5	M ¹ B×1	25.4	TR-06
15	12.7	M22×1	28	TR-0B
17	16.0	M25×1	31. B	TH-10
19	19.0	M2B×1	35.6	TR-12
21	22.2	M31×1	38	TR-14
23	25.4	M34×1	40	TR-16

Model example:

The D38999m11FJCOOF-7.9 model is a version without the Ti-Ni ring. When a matching Ti-Ni ring is required, the model is D38999III11FJCOOFA-05.

MIL-DTL-38999 Series III Composite Connectors

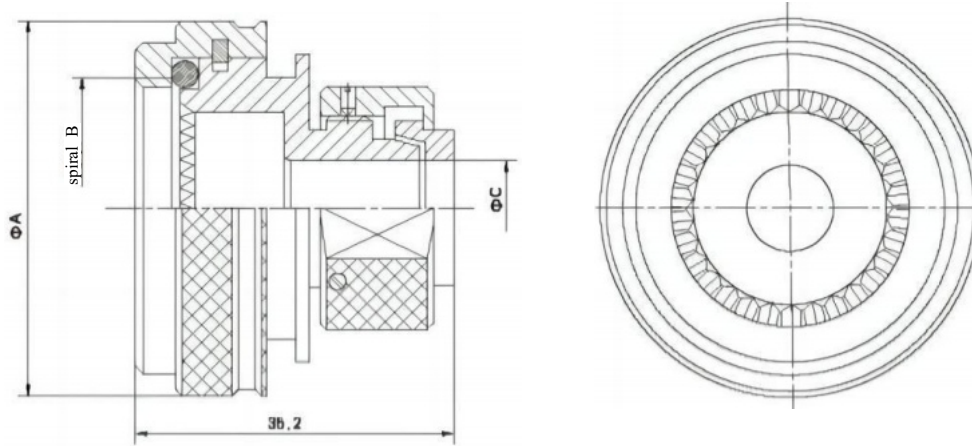

Shell number	A	Screw thread BUNE	C Outlet diameter
08	18.0	M12×1	6.3、7.8、Ø.5
11	21.6	M15×1	6.3、7.9、9.5、11.1、12.7
13	26.4	M18×1	6.3、7.9、9.5、11.1、12.7、16
15	28.0	M22×1	7.9、9.5、11.1、12.7、16、19
17	31.8	M25×1	7.9、9.5、11.1、12.7、16、19、22.2
19	35.8	M28×1	12.7、16、19、22.2、25.4
21	38.0	M31×1	12.7、16、19、22.2、25.4、28.5
23	40.0	M34×1	16、19、22.2、25.4、28.5、31.8
25	44.5	M37×1	19、22.2、25.4、28.5、31.8、35

This type of tail attachment can press the shielding net and is waterproof (customizable by users).

Product Logo Code

HL J599 III 23 YGD25 F - 14
 1 2 3 4 5 6 7

1—Taizhou Hanglong Electronics Co., Ltd. Corporate Name

2—Basic component number

3 Series 1, Code III

4—Case numbers: 09,11,13,15,17,19,21,23,25

5. Structural form: Adopting the YGD curved tail design

6—Shell coating: W-plating with military green F-chemical nickel plating

7—Outlet diameter

MIL-DTL-38999 Series III Composite Connectors

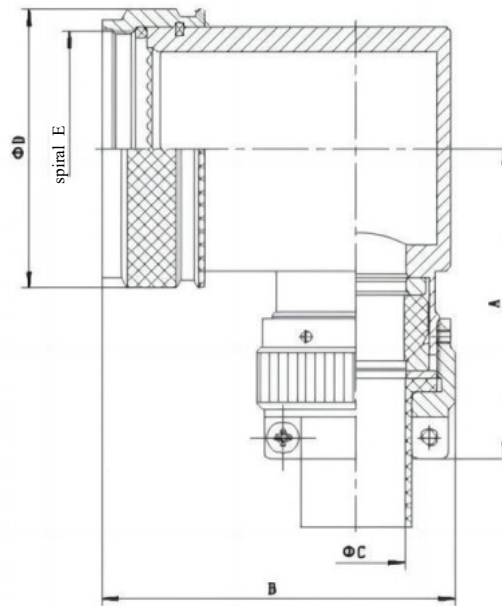

Shell number	A	B	C	D	Screw thread E
23	44.5	50.5	14	40	M34 × 1-6H
25	46	51.5	15	44.5	M37 × 1-6H

Roundplate with rubber pad

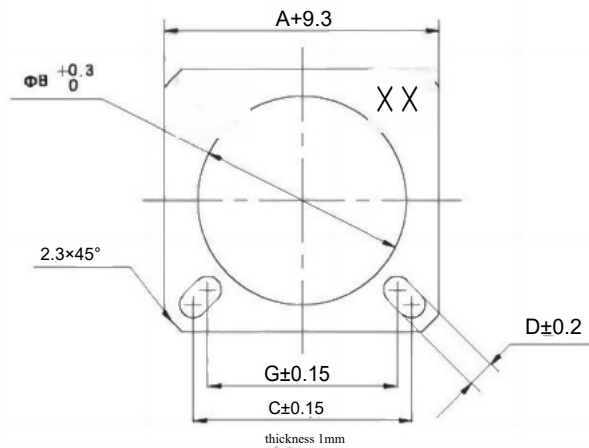

Adapt shell number	Code for square plate rubber pad	Conductive square plate Gum pad code	A	B	C	G	D
A	21E8.701.886	21E8.701.886	23.9	16.1	18.26	15.00	3.3
B	21E8.701.887	21E8.701.888	26.3	19.2	20.62	18.26	3.3
C	21E8.701.889	21E8.701.890	28.7	22.4	23.01	20.62	3.3
D	21E8.701.891	21E8.701.892	31.1	25.6	24.61	23.01	3.3
E	21EB.701.893	21EB.701.894	33.4	30.4	26.97	24.61	3.3
F	21EB.701.895	21EB.701.896	36.6	32.0	29.36	26.97	3.3
G	21EB.701.897	21EB.701.898	39.8	34.9	31.75	29.36	3.3
H	21E8.701.899	21E8.701.900	43.0	38.3	34.93	31.75	4.0
J	21EB.701.901	21EB.701.902	46.1	41.4	38.10	34.93	4.0

MIL-DTL-38999 Series III Composite Connectors

Special Contact Parts for GJB599III Series

Contact specifications	American Standard Model	National Standard Model	Remarks
Pin 12#	M39029/58-365	J1216/58-365	
12# socket	M39029/56-353	J1216/56-353	
Pin 12#	M39029/107-623	J1216/107-623	Lifespan: 1500 cycles
12# socket	M39029/106-617	J1216/106-617	Lifespan: 1500 cycles
12# shielded pin	M39029/28-211	J1216/28-211	
12# Shielded socket	M39029/75-416	J1216/75-416	
12# coaxial pin	M39029/102-558	J1216/102-558	
12# coaxial socket	M39029/103-55B	J1216/103-559	
Japanese #Dual coaxial pin	M39029/90-529	J1216/90-529	
B# Double coaxial socket	M39029/91-530	J1216/91-530	
B# Analog Contact		J1784A/B0-8	
12# simulated contact piece		J ¹ 784A/80-12	
8# Sealing plug	MS27488-B (red)	JY27488-B (red)	
10# Sealing plug	MS27488-10 (White)	JY27488-10 (White)	
12# Sealing plug	MS27488-12 (Yellow)	JY27488-12 (Yellow)	

MIL-DTL-38999 Series Power Connectors

The series of round electrical connectors meet the GJB599A (MIL-C-38999) Series III requirements, designed for power supply applications with rated operating currents ranging from 7.5A to 225A. They feature threaded quick-connects with anti-disengagement mechanisms. The product's tail end is terminated by crimping, and both plugs and sockets can be installed in either pin or hole configurations.

Product Logo Code

HL J599/ 20 W G 05 P N
1 2 3 4 5 6 7 8

1 Qinzhou Hanglong Electronics Co., Ltd. enterprise name

2— Basic serial number

3— Shell type: 20-square socket, 24-nut fastening socket, 26-shielded plug

4 1. Coating: W-coated cadmium
military green
F-chemically plated nickel
K-stainless steel passivation

5— Shell number: A to J

Index number

09 11 13 15 17 19 21 23 25
A B C D E F G H J

6— Contact arrangement: See the Contact Arrangement Diagram

7— Contact type: P-Pressed pin, PH-Soldered pin;
S-Pressed hole, SH-Soldered hole

8 One key position: N-normal key position

A,B, C, D, E – One variable position

Product Technical Characteristics

I. Environmental Conditions for Use

Temperature range: Class W: 65°C to 175°C

Class F and K: -65°C to 200°C

Seal: The plug-in connector complies with the MIL-C-38999K low-pressure immersion test requirements.

Salt spray: Method 1001 in GJB 1217

500 hours (Class W)

4B hours (Category F)

1000 hours (Class K)

Hot and humid: per MIL-C-38999K:10 cycles in 24 hours

Fuel-resistant: Resistant to various fuels, coolants, and solvents

II. Electrical Performance

rated voltage, withstand voltage and insulation resistance

Work environment	Rated voltage V	Withstand voltage V	Insulation resistance MΩ
Room temperature	500	1500	>5000
Damp-heat condition	500	750	>1000

conductive property of shell

Class: 2.5 mΩ

Class F: 1 mΩ

Class K: 5 mΩ

Shielding capability reaches 65dB(F) at 10 GHz

50dB (W) at 10GHz

At 1GH, the value reaches 85dB (F and W).

Contact resistance and rated current of contact

Contact specifications	Contact resistance mΩ	Rated current A
20#	≤8.5	7.5
16#	≤4.5	13
12#	≤2.2	23
10#	≤1.2	33
8#	≤0.7	46
6#	≤0.5	50
4#	≤0.35	B0
0#	≤0.17	150
2/0#	≤0.124	185
4/0#	≤0.116	225

MIL-DTL-38999 Series Power Connectors

III. Mechanical Properties

Shell: Aluminum alloy, Stainless steel

Plating: W-Cadmium-plated military green F-Chemical nickel plating K-Stainless steel passivation

Insulator: thermoplastic or thermosetting material

Sealing body and sealing ring: silicone rubber

Contact: Gold-plated copper alloy

Mechanical lifespan: ≥ 500 insertions and extractions

Impact: 3ms half-sine wave acceleration peak 300g

Vibration: Sine wave: 60g, with temperature cycling and simulation

accessories (36 hours) Random: 44.1gms at high temperature

49.5 grams at ambient temperature

IV. Contact Arrangement (View of Needle Insulator Insertion Surface)

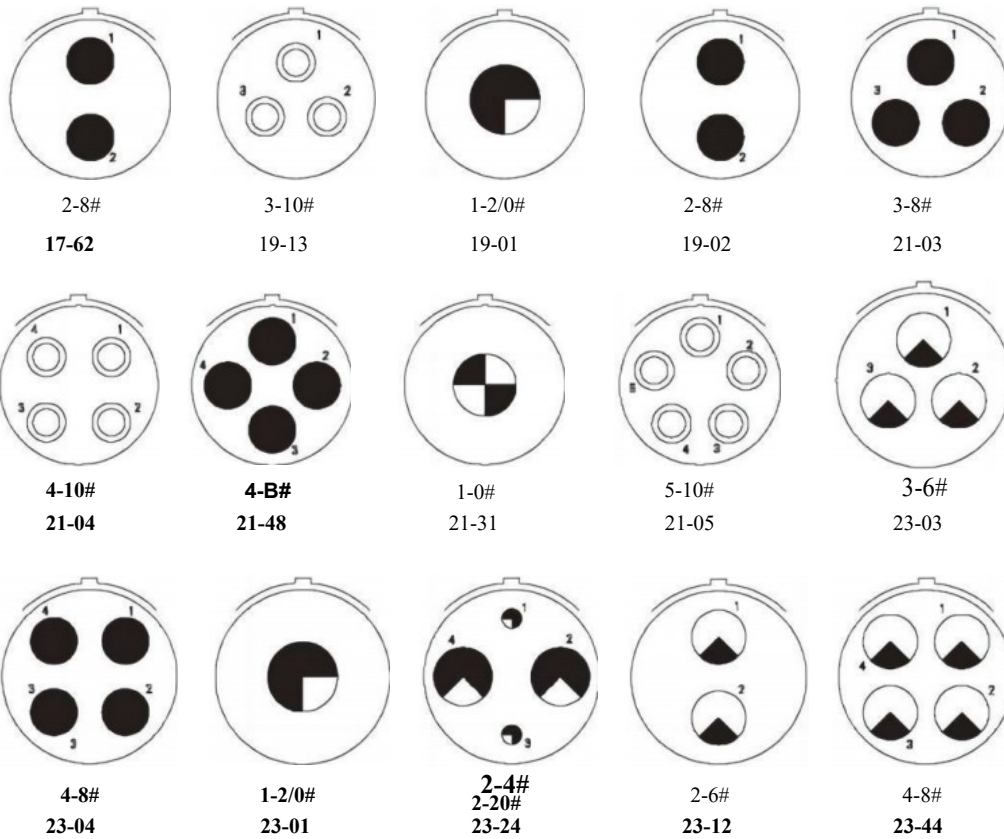

MIL-DTL-38999 Series Power Connectors

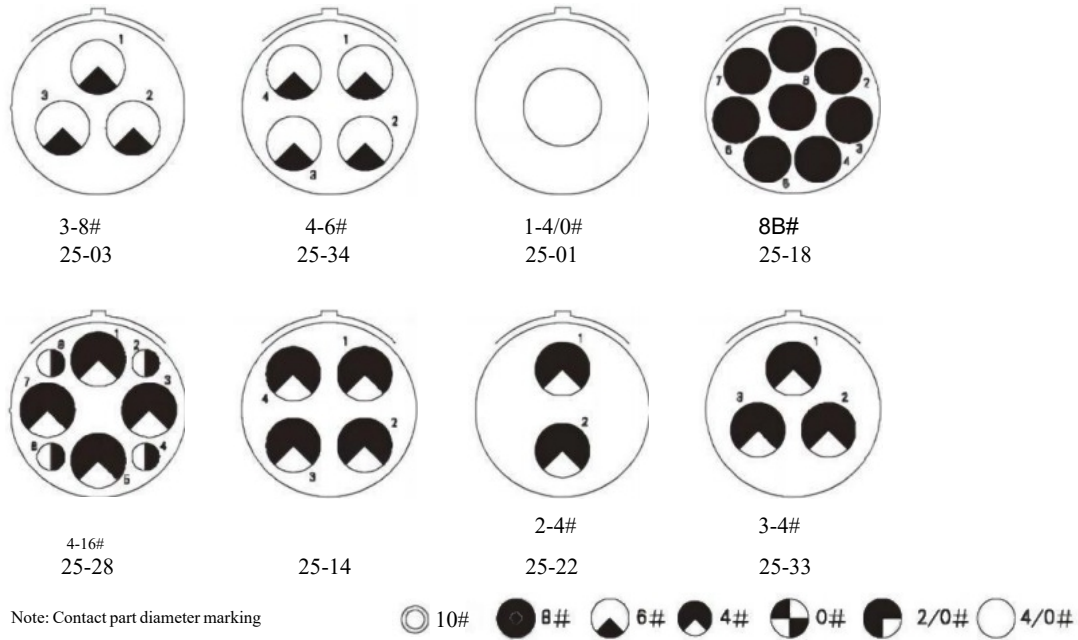

V. Pressed Contact Parts

Contact specifications	Insertion end diameter (mm)	Adapt wire cross-section (mm ²)	Adapt to US standard cable
20#	1.00	0.2-0.5	20, 22, 24
16#	1.60	0.5~1.2	16, 18, 20
12#	2.40	2.0-3.0	12, 14
10#	3.15	4.B-8.6	8, 10
8#	3.61	10.5~13.3	6, 7
6#	4.52	16.7~21.2	4, 5
4#	5.72	21.2-26.7	3, 4
0#	9.07	42.4~53.5	0, 1
2/0#	10.31	53.5~67.5	0, 00
4/0#	13.00	67.5-85.0	00, 000

VI. Dimensions

GJB599Ⅲ Series Electrical Connector

Appendix 1: Instructions for Using GJB599 Series Product Pressing Tools

principle of crimping

Soldering is a permanent connection method. The process involves wrapping bare wires with metal conductors at the terminal ends, then mechanically pressing the wire bundle using manual or automated specialized tools. This technique connects wires to contact parts through controlled deformation of the metal within specified parameters. High-quality soldering features metal flow and mutual fusion, resulting in symmetrical deformation of the stranded wires and contact materials. Similar to cold welding, this connection ensures both mechanical strength and electrical continuity.

The conductor is formed by twisting multiple single-strand round cores, creating gaps between each core wire. When the twisted circle deforms beyond its diameter d (as shown in Figure 1), the original twisting pattern is disrupted, causing gaps to fill. As these gaps fill and continue to deform, plastic deformation occurs between the core wires and against the inner wall of the crimping tube, generating static friction. The metal molecules interpenetrate, resulting in the "cold welding" phenomenon. The crimping process increases the contact area between the contact piece and the conductor, leading to lower contact resistance and higher tensile strength.

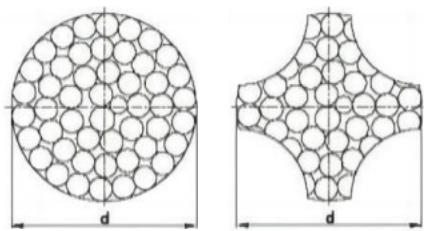

Graph 1

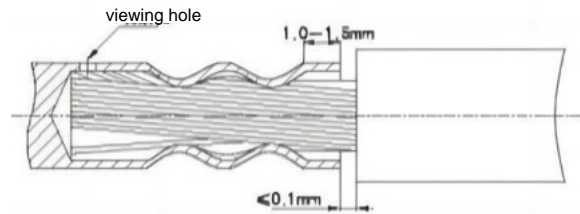

Graph 2

crimping characteristic

Connectors with crimped contacts typically allow for contact replacement, including adjustments, circuit modifications, faulty contact replacement, or switching to alternative contacts during production. Crimping can be performed using manual tools, power tools, or automatic crimping machines. The crimping tools must be regularly calibrated to ensure proper crimp strength. Each contact's observation port provides visibility of the stranded wire ends, ensuring the wires are correctly positioned when inserted into the contact crimping cylinder.

crimping tool

The crimping tool is a special tool for transferring the crimping force, which is the key to ensure the reliability of crimping. Taking the manual crimping tool as an example, it generally consists of four parts: the crimping head, the self-locking mechanism, the positioner, and the handle.

The pressing head section—consists of the pressing head, reset spring, and frame. The shape of the pressing head determines the form of the indentation, while the strength and wear resistance of the pressing head are critical.

Self-locking mechanism — including rack, adjusting cam, spring, etc. The self-locking mechanism is critical for ensuring crimping strength while preventing the handle from releasing when crimping is incomplete. Different crimping strength requirements are controlled by adjusting the cam according to the specifications of different contact parts.

The locator is a device to ensure the axial positioning of the crimping position, which can be loaded and unloaded.

Handle – used to apply force.

According to the contact piece specifications of GJB599 series products and the requirements of MIL-C-22520 crimping pliers specifications, our company has developed two types of crimping pliers for GJB599 series products: \times CXY-01 and YJO. The \times CXY-01 crimping pliers are mainly used for crimping larger specifications of 20#, 16#, and 12# contact pieces, while the YJO is a small crimping plier designed for smaller specifications such as 22D# and 20# contact pieces.

Appendix 1: Instructions for Using MIL-DTL-38999 Series Product Pressing Tools

XCXY-01 crimping pliers

1、 Axial Positioner

The axial locator secures contact parts axially to ensure precise and reliable crimping positions. The XCXY-01 crimping pliers feature three adjustable locators (see Figure 3) for different contact part specifications, as detailed in Table 1.

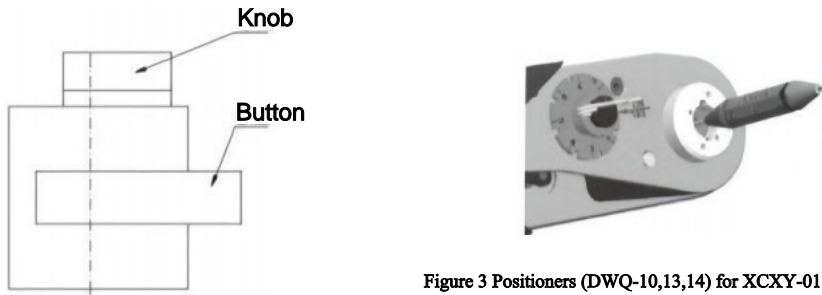

Figure 3 Positioners (DWQ-10,13,14) for XCXY-01 Crimping Pliers

Table 1

Crimping pliers model	Adapter locator	Specification of pressure fitting
XCXY-01	DWQ-10	G.B6991, III-series 20 ", 16", and 12" socket contact parts
	DWa-13	G.B59I, II, III series 20 ", 18", 12" pin contact parts
	DW0-14	GJB689II Series 20#,16 ", 12" socket contact parts

2、 radial locator

The radial locator is an eight-position rotary disc, with each position controlling the crimping strength of the contact piece. By adjusting the positions, it can meet the crimping strength requirements for various contact pieces when crimping wires of different specifications. See Table 2 for details.

Table 2

Pinhole size	20 "			16"			12*	
Outer diameter of wire roll (mm)	1.78			2.62			3.84	
Inner diameter of the wire roll (mm)	1.17			1.68			2.48	
Radial selector position number	8			6			4	3
Adapted wire (AWG)	24	22	20	20	18	16	14	12
Crimping contact resistance (mΩ)	1.0	0.8	0.7	0.7	0.5	0.4	0.3	0.2
Crimping strength (N)	30	49	74	74	187	206	314	471

3、 Crimping Procedure

3.1 Install the axial locator: Secure the axial locator onto the crimping pliers using a hex key.

3.2 Selection of axial positioners: The knob of the axial positioner is equipped with a positioning device compatible with various contactor specifications. The knob is eccentrically mounted, allowing the positioning device for the required contactor size to be centered through rotation.



Appendix 1: Instructions for Using MIL-DTL-38999 Series Product Pressing Tools

- a. Rotate the knob (if it doesn't extend, press the button to hear a 'click' and the knob will pop out), then adjust the locator to the center position of the required contact part.
- b. Press the knob downward. You'll hear a 'click' sound, indicating the button is fully pressed and the shaft is securely fixed.



3.3 Radial positioning selection: Radial positioning selection is completed by adjusting the rotating disk, which is engraved with eight different scales to suit different contact parts and matching wire crimping.

- a. According to the specification of the contact piece pressed, the wire specification is selected and the radial selection number is determined through Table 2.
- b. Remove the locking pin, lift the rotating disc, and turn the desired number to the arrow-marked line.
- c. Release the turntable, fasten the locking pin, and complete the radial adjustment.



3.4 Crimping Operation Steps

- a. Prepare the crimping component: Select the wire according to the contact specifications in Table 2, remove the insulation, and insert the stripped core into the contact with a length of 6.5–7.0 mm.

The wire core should extend beyond the observation hole on the crimping tube (see Figure 4).

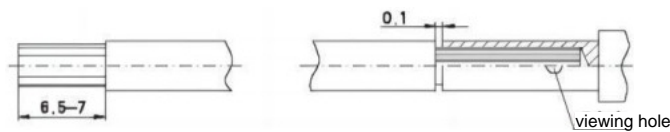

Graph 4

- b. Pressing: Insert the component to be pressed into the hole of the clamp mouth, ensuring the contact end touches the bottom of the positioning hole. Hold the handle in the locked position, release the handle, and remove the component.

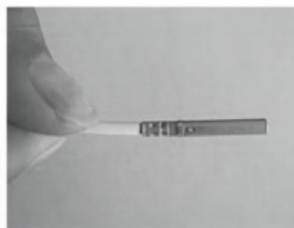

Appendix 1: Instructions for Using MIL-DTL-38999 Series Product Pressing Tools

3.5 Check the Crimping Quality

The following aspects should be primarily inspected after crimping:

a. Appearance: Check for uniform crimping points and bending at crimping sites, as shown in Figure 2.

b. Crimping strength: Verify whether the crimping strength meets the specified requirements, as shown in Table 2.c.

c. Contact resistance value: Check whether the contact resistance value meets the specified requirements, as shown in Table 2.

YJO crimping pliers

1、axial positioner

The axial locator is used to fix the contact parts axially, ensuring correct and reliable crimping positions. The YJQ crimping pliers are equipped with four specifications of locators, as shown in Figure 5, to accommodate...

Use contact parts of different specifications, as detailed in Table 3:

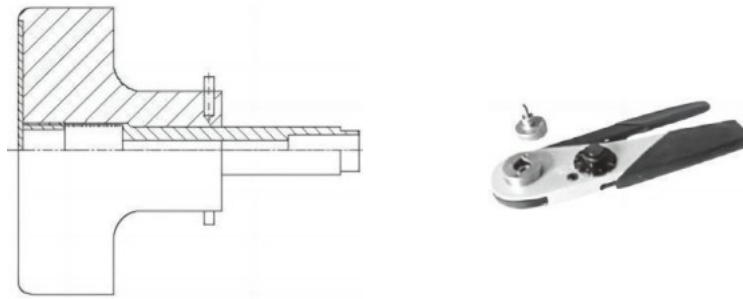

Figure 5: Positioners (XDWQ-03Z,03K,06,07) for YJQ crimping pliers; Table 3

Crimping pliers model	Adapter locator	Specification of pressure fitting
YJO	XDWa-03Z	G.B599I, Series II and III 22D® Pin Contact Parts
	XDWO-03K	GJB599I, Series III 22" socket contact
	XDWQ-06	GJB599I Series 20D Socket Contact
	XDWQ-07	GJB599I, II, III series 20-pin contact components GJB599II Series 20" Socket Contact

2、radial locator

The radial locator is an eight-position rotary disc, with each position controlling the crimping strength of the contact piece. By adjusting the positions, it can meet the crimping strength requirements for various contact pieces when crimping wires of different specifications. See Table 4 for details.

Table 4

Pinhole size	22D#				20#		
Outer diameter of wire roll (mm)	1.22				1.78		
Inner diameter of the wire roll (mm)	0.85				1.17		
Radial selector position number	1				2	3	
Adapted wire (AWG)	28	26	24	22	24	22	20
Crimping contact resistance (mΩ)	1.2	1.1	1.0	0.8	1.0	0.8	0.7
Crimping strength (N)	13	22	30	49	30	49	74

3、crimping procedure

The crimping procedure is largely identical to that of the XCXY-01 crimping pliers, with the sole difference being the ease of installation for the YJO axial locator, which can be secured by simply rotating the locator 90°.

Precautions for crimping

- 1、 The conductor cross-section must be selected according to the provisions of Table 2 and Table 4 to match the corresponding contact parts.
- 2、 Use wire stripping pliers for wire stripping without damaging the conductor, and the conductor must not be broken. After stripping, conductors must pass quality inspection: the length of the stripped wire must comply with the specifications in Figure 4.
- 3、 After adjusting the crimping pliers, perform two air compressions to verify their smooth operation.
- 4、 Never press large-diameter contact parts onto the crimping position of small-diameter ones, as this may prevent the handle from reaching the closed position. Forcing the handle to close could damage the crimping pliers. If this occurs, contact the supplier for repair.
- 5、 When crimping the contact piece of the socket, the crimping position must be clearly identified.
It is strictly prohibited to use the socket contact end as the crimping tube for crimping.
- 6、 When performing crimping, always use the correct crimping tool and never use incompatible tools.
- 7、 In order to ensure the quality of the batch production, it is recommended to conduct a trial crimping test on each type of contact piece (the quantity is self-determined) with each crimping tool before the crimping of each batch of products, and to perform a pull-off test. Only after passing these tests should the batch crimping proceed.
- 8、 The crimping site must be kept clean. Conductors should be stripped before individual crimping. During crimping, the connector interface must be covered with a protective cap to prevent foreign matter from entering.
- 9、 The crimping tool shall be inspected regularly and only used after passing the inspection.
10. It is forbidden to weld the wire with the crimping contact piece, which is not good for the contact piece to be installed.

Appendix 2: Assembly Instructions for GJB599 Series High-Frequency Contact Components

1. Comparison of High-Frequency Contact Components (Domestic and International Models) and Corresponding Cables Table 1: Model Comparison and Compatible Cables

Contact specifications	National Standard Model	Foreign model	Adapter lead	
			Domestic wire	Foreign wire
16# fern pin	J1216/76—424	M39029/76—424	SYV—50—2—51	M17/113—RG316
16# Shielded socket	J1216/77—428	M39029/77—428	SFF—50—1.5—51 SFF—75—1.6—51	
12# fern pin	J1216/2B—211	M39029/28—211	SYV—50—2—51	
12# Shielded socket	J1216/75—416	M39029/75—416	SFF—50—1.5—51	M17/113—RG316
12# coaxial pin	J1216/102—558	M39029/102—558	SFF—50—2—51	M17/113—RG316
12# coaxial socket	J1216/103—559	M3B029/103—558	SF—75—1.5—51	
B# double coaxial shielded pin	J121B/90—529	M39029/90—529	SEF—78—1—51	M17/176—00002
8# Double Coaxial Shielded Bundle	J121B/91—530	M39029/91—530		
B# Differential 2-pin 1000	CF ⁸ 1/211—01			
8# Differential 2-core Spreading Hole 1000	CF82/211—01			
B# Differential 4-pin 1000	CFB1/411—01			
8# Differential 4-core Rebar with 1000mm Hole	CFB2/411—01			

Tensile Strength After Crimping (Table 2)

Wire code	Maximum tensile strength (N)		
	Central contact	Intermediate contact	External contact
SYV—50—2—51	66.72		66.72
SFF—50—1.5—51	44, 48		66.72
SF 76-1.6-51	15, 67		86, 72
M17/113—RG316	86.72		88.72
SEF—78—1—51	35.59	35.59	111.21
M17/176—00002	35.59	35.59	111.21

High Frequency Contact Assembly

load contact

When assembling contact parts, use the "IN" end of the plastic loading tool with matching phase specifications. The procedure is as follows: First, thread the wire through the "N" end of the plastic loading tool, then push the "IN" end of the tool toward the tail of the contact part. Insert the wire along the hole position until the stopper is reached, then withdraw the tool. Gently pull the wire out by hand; the contact part should not be pulled out.

unload contact

The "EX" end of the corresponding plastic loading/unloading tool is used for removing the contact piece. The procedure is as follows: First, insert the wire into the "EX" end of the plastic loading/unloading tool. Then insert the tool along the hole position into the tail of the contact piece until it stops moving, then pull the wire to remove the contact piece.

16# Shielded Contact Assembly

16# Shielded Pin Assembly Instructions (RG316)

① As shown in Figure 1, peel the cable with the end face cleanly cut perpendicular to the axial plane. Ensure the cable remains undistorted during cutting. Hot peeling is recommended.

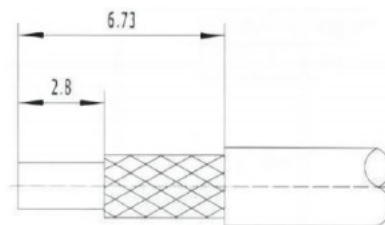

Graph 1

② As shown in Figure 2, slide the crimp sleeve backward onto the cable sheath, then spread the shielding layer and remove the cable insulation.

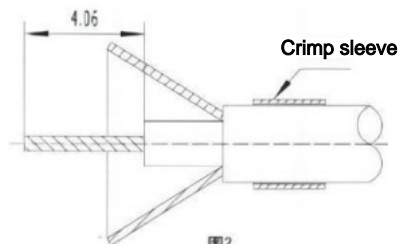

③ The rear end insulator is mounted on the central conductor of the cable, and the tail of the rear end insulator is tightly pressed against the cable insulation medium.

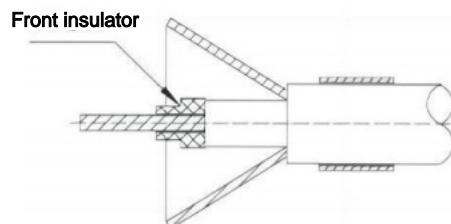

Graph 3

④ As shown in Figure 4, install the center plug hole onto the cable's central conductor. The conductor can be visually inspected through the observation port at the plug hole's rear. Use the M22520/2-01 crimping pliers (position 5) with the M22520/2-35 positioning tool for secure crimping.

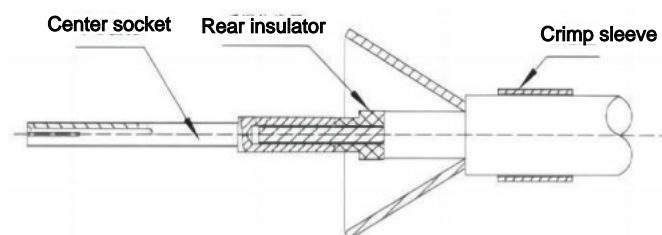

Graph 4

⑤ Then, install the front insulator onto the central socket according to Figure 5, ensuring its tail tightly adjoins the step portion of the rear insulator.

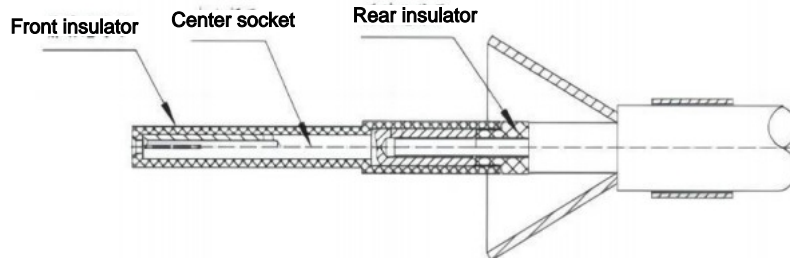

Graph 5

According to Figure 6 install the external pin onto the center hole of the crimped and insulated component until the internal contact and the insulator are fully pressed together.

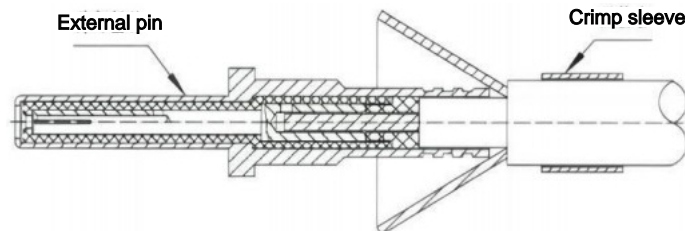

Graph 6

⑦ As shown in Figure 7, position the crimping sleeve forward on the cable shielding layer at dimensions 6.1-6.8. Trim the excess shielding material beyond the sleeve, then crimp it using the M22520/4-01 tool and M22520/4-02 locator. After the first crimping, rotate the contact piece 45 degrees before the second crimping. The diameter of the crimped shielding sleeve must not exceed 2.74 mm.

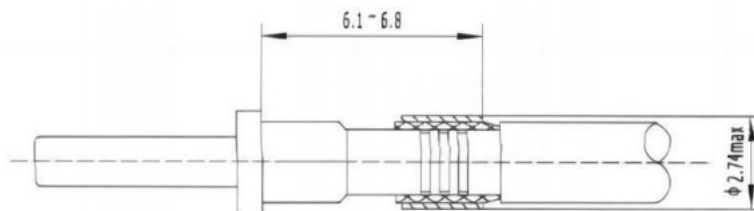

Graph 7

16# Shielded Socket Assembly

① As shown in Figure 8, peel the cable with the end face cleanly cut perpendicular to the axial plane. Ensure the cable remains undistorted during cutting. Thermal stripping is recommended.

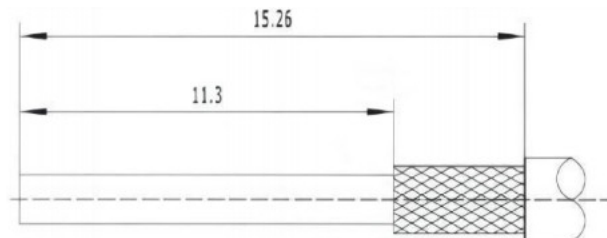

Graph 8

Appendix 2: Assembly Instructions for MIL-DTL-38999 Series High-Frequency Contact Components

② As shown in Figure 9, slide the crimping sleeve backward onto the cable sheath, then spread the shielding layer and remove the cable insulation.

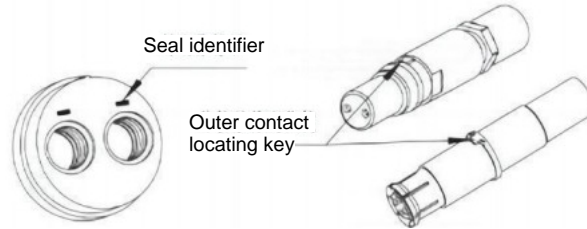

Graph 9

③ As shown in Figure 10, slide the rear insulator onto the cable's central conductor, ensuring its tail contacts the cable's insulating medium.

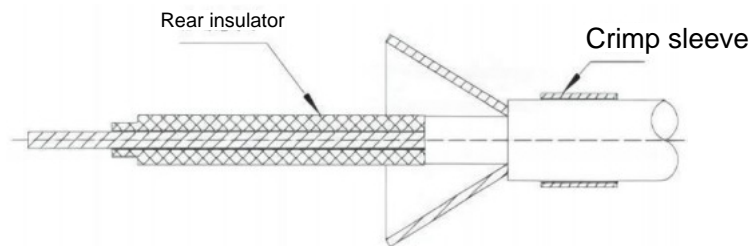

Graph 10

④ As shown in Figure 11, install the center plug hole onto the cable's central conductor. The conductor can be visually inspected through the observation port at the plug hole's rear. Use the crimping tool M22520/2-01 (position 5) with the locator M22520/2-35 for crimping.

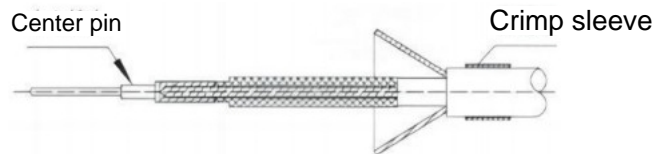

Graph 11

⑤ As shown in Figure 12, install the front-end insulators onto the central socket, ensuring the contact areas of the two insulators are tightly pressed together.

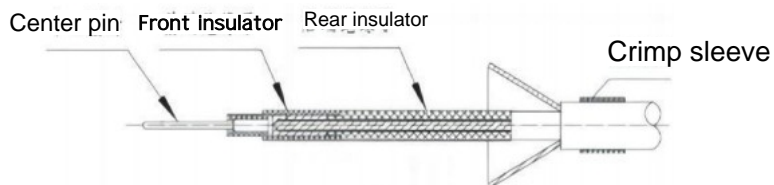

Graph 12

⑥ As shown in Figure 13, install the external contact onto the central contact beneath the cable shielding layer until both the central contact and the insulator are fully secured.

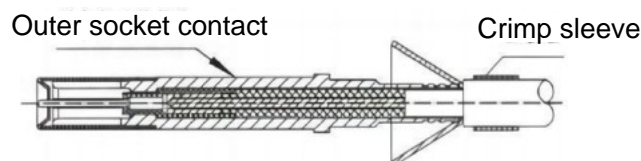

Graph 13

⑦ Position the shielding crimping sleeve over the cable's shielding layer as shown in Figure 14, with the dimensions ranging from 6.1 to 6.8. Trim any excess shielding material beyond the sleeve. Use the M22520/4-01 tool and M22520/4-02 locator to crimp the sleeve: perform the first crimp, then rotate the contact piece 45 degrees before the second crimp. After the second crimp, the diameter of the shielding crimping sleeve must not exceed 2.74.

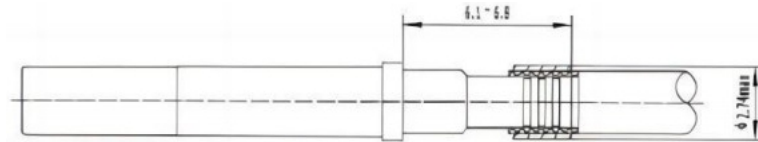

Graph 14

Assembly of 12# Shielded Contact

1 2 # ASPECTIVE PUNCTURE PINS

① As shown in Figure 15, when stripping the cable, the end must be cleanly cut at a right angle to the cable's axis. The cable must not be deformed during the cutting process.

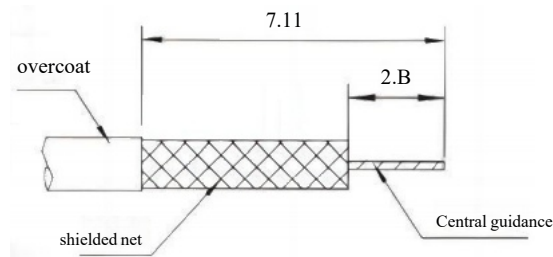

Graph 15

② The shielding mesh compression sleeve is put on the cable jacket as shown in Figure 16.

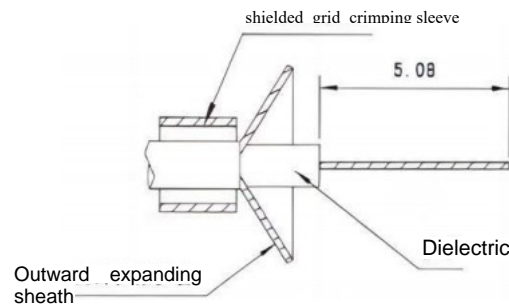

Graph 16

③ Open the shielding layer outward and peel off the dielectric part of the cable.

④ As shown in Figure 17, the central conductor passes through the insulator until the bottom portion of the insulator tail depression is in contact with the dielectric and under the cable shielding net.

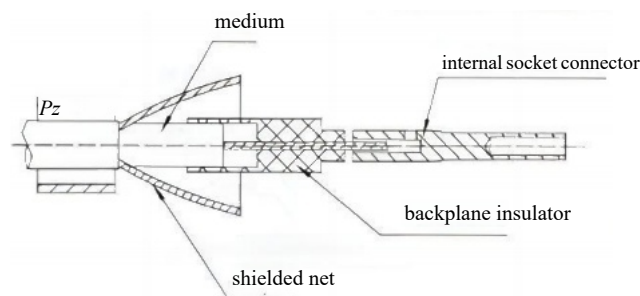

Graph 17

Appendix 2: Assembly Instructions for MIL-DTL-38999 Series High-Frequency Contact Components

- ⑤ Insert the cable's central conductor into the contact piece's central hole. The conductor should be clearly visible through the observation window on the contact piece. The contact piece must firmly press against the rear end insulator.
- ⑥ Use the crimping tool M22520/2-01 and the locator M22520/2-34 to crimp the internal plug contact.
- ⑦ As shown in Figure 18, install the internal components from Figure 17 into the external pin contact until the cable shielding mesh is fully secured, ensuring complete installation of the internal pin contact.

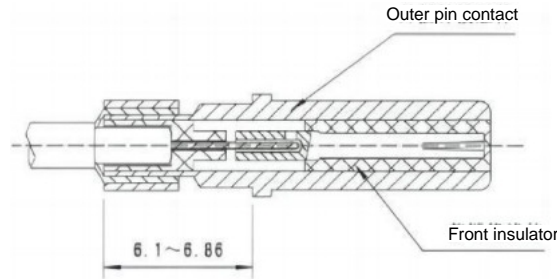

Graph 18

- ⑧ Advance the shielding mesh crimping sleeve to maintain the 6.1-6.8mm dimension. Trim the excess shielding mesh at the front end of the sleeve. Use the crimping tool M22520/31-01 and the locator M22520/31-02 specified in Table 3 to crimp the shielding mesh crimp sleeve. Perform the first crimping, rotate the contact assembly 45 degrees, and then perform the second crimping. After the second crimping, the outer diameter of the shielding mesh crimp sleeve must be less than 3.96 mm.
- ⑤ Figure 19 shows the crimped 12# shielded pin.

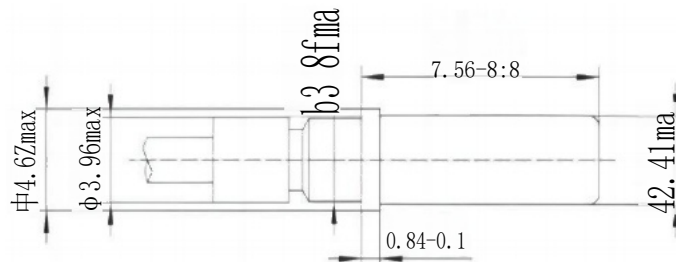

Graph 19

Assembly of 12# Shielded Socket

- ① As shown in Figure 20, when stripping the cable, the end must be cleanly cut at a right angle to the cable's axis. The cable must not be deformed during cutting.

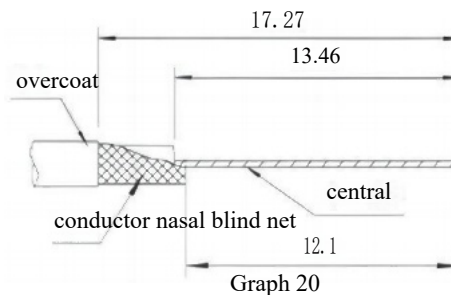

Graph 20

- ② As shown in Figure 21, follow these instructions:
 - a. The shielding mesh pressure fitting sleeve is put on the cable sheath.
 - b. As shown in the figure, gradually expand the shielding layer outward to peel off the cable's dielectric layer.
 - c. The central conductor is threaded through the insulator until the dielectric base contacts the rear end of the insulator.
 - d. Insert the cable's central conductor into the internal pin contact. The inner conductor must be visible through the observation hole on the contact. The contact must press against the front end of the insulator.
 - e. Use the crimping tool M22520/2-01 and the locator M22520/2-34 listed in Table 3 to crimp the internal contact pin.

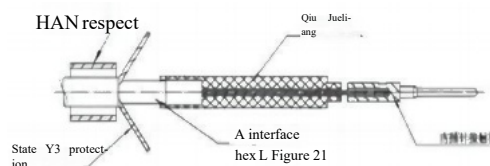

③ As shown in Figure 22, follow these instructions:

- a. Insert the internal components of Figure 7 into the external contact assembly until the inner pin contact is fully installed.
- b. Advance the shielding mesh crimping sleeve to maintain the 6.1~6.8mm dimension. Trim the excess shielding mesh at the front end of the sleeve.
- c. Use the crimping tools and aligners specified in Table 3 to crimp the shielding mesh sleeve. First crimp, then rotate the contact assembly 45° before the second crimp. After the second crimp, the outer diameter of the sheath crimp sleeve must not exceed 3.96mm.

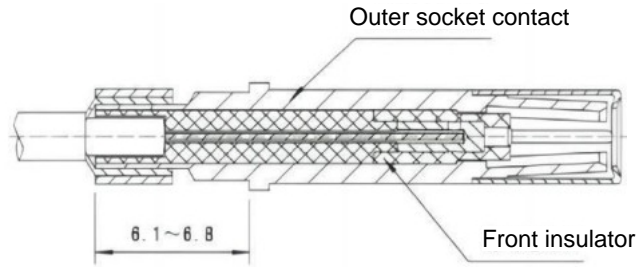

Graph 22

④ Figure 23 shows the crimped 12# shielded socket.

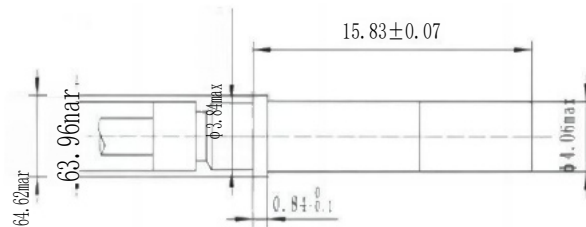

Graph 23

Assembly of 12# coaxial contact and 12# coaxial pin

① As shown in Figure 24, strip the cable. The ends must be cleanly cut at a right angle to the cable's axis. During cutting, ensure the cable remains undistorted.

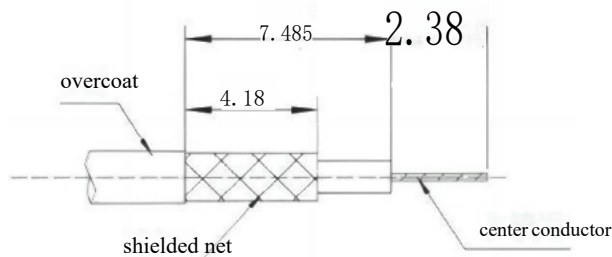

Graph 24

② As shown in Figure 25, the shielding mesh crimping sleeve is installed over the cable jacket.

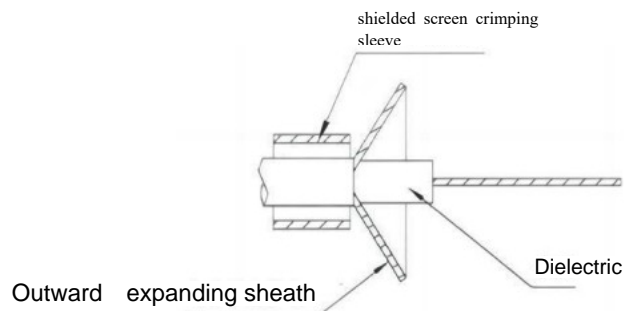

Graph 25

- ③ Open the shielding layer outward and peel off the dielectric part of the cable.
- ④ In Figure 26, the cable's central conductor is inserted into the contact piece of the central hole. The conductor can be clearly observed through the observation hole on the contact piece. The contact piece must firmly press against the rear end insulator.

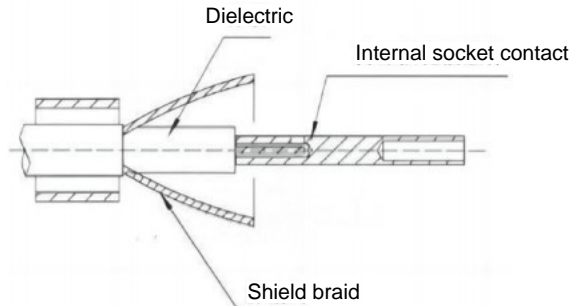

Graph 26

- ⑤ Use the crimping tool MH992 and the locator K1303S to crimp the internal plug contact.
- ⑥ As shown in Figure 27, install the internal components from Figure 17 into the external pin contact until the cable shielding mesh is fully secured, ensuring complete installation of the internal pin contact.

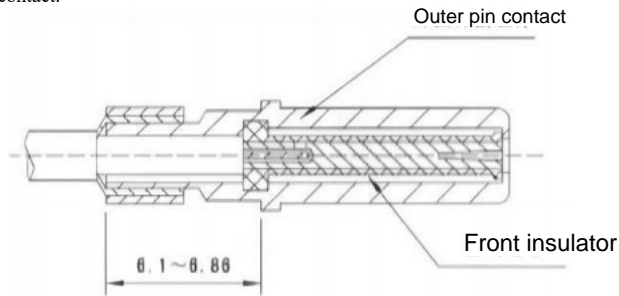

Graph 27

- ⑦ Advance the shielding mesh crimping sleeve to maintain the 6.1-6.8mm dimension. Trim the excess shielding mesh at the front end of the sleeve. Use the crimping tool M22520/31-01 and the locator M22520/31-02 specified in Table 3 to crimp the shielding mesh sleeve: First crimp, rotate the contact assembly 45 degrees, then perform a second crimp. After the second crimp, the outer diameter of the shielding mesh sleeve must be less than 3.96mm.

- ⑧ Figure 28 shows the crimped 12# shielded pin.

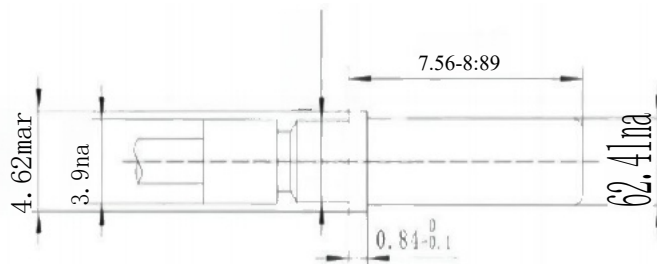

Graph 28

1 2 # Assembly of coaxial socket

- ① As shown in Figure 29, strip the cable. The ends must be cleanly cut at a right angle to the cable's axis. During cutting, ensure the cable remains undistorted.

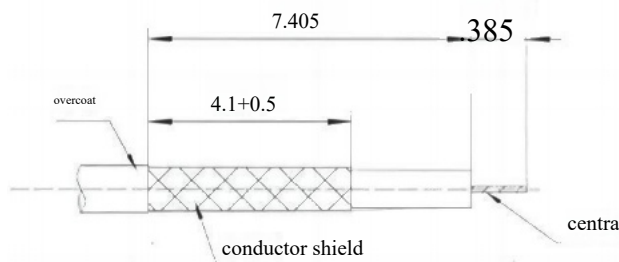

Graph 29

Appendix 2: Assembly Instructions for MIL-DTL-38999 Series High-Frequency Contact Components

② As shown in Figure 30, follow these instructions:

- a. The shielding mesh pressure fitting sleeve is put on the cable sheath.
- b. As shown in the figure, gradually expand the shielding layer outward to peel off the cable's dielectric layer.
- c. Insert the cable's central conductor into the internal pin contact. The inner conductor must be visible through the observation hole on the contact. The contact must press against the front end of the insulator.
- d. Use the crimping tool MH992 and the locator K1304 listed in Table 3 to crimp the inner pin contact.

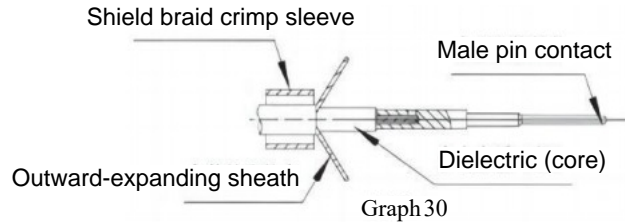

③ As shown in Figure 31, the following requirements are to be followed:

Insert the internal components of Figure 30 into the external contact assembly until the inner pin contact is fully installed.

- b. Advance the shielding mesh crimping sleeve to maintain the 6.1~6.8mm dimension. Trim the excess shielding mesh at the front end of the sleeve.
- c. Use the crimping tool M22520/5-01 and the locator M22520/5-03 listed in Table 3 to crimp the shielding net crimping sleeve. The outer diameter of the sheath crimping sleeve must not exceed 3.96mm.

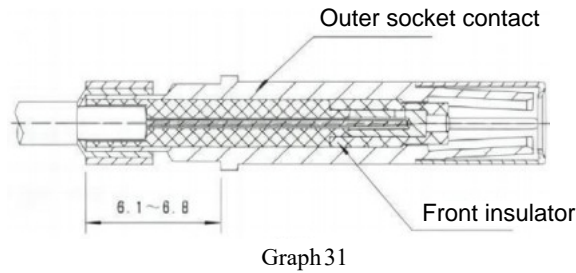

④ Figure 32 shows the crimped 12# coaxial socket.

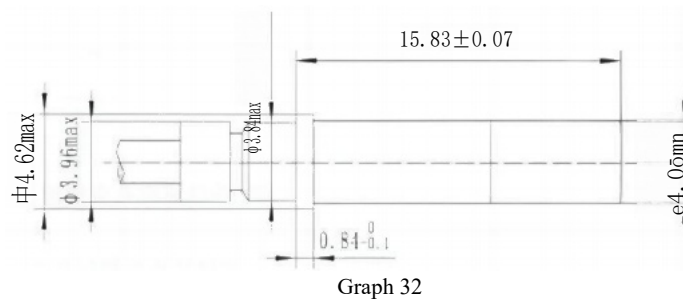

Assembly of 12# Double Coaxial Shielded Contact

Assembly of 12# Double Coaxial Shielded Pin

① As shown in Figure 33, follow these requirements:

- a. As shown in the figure, the heat shrink sleeve is fitted over the cable.
- b. Remove the cable sheath to the position shown in the diagram. The end must be cleanly cut at a right angle to the cable's axis. During cutting, ensure the cable remains undistorted and undamaged.

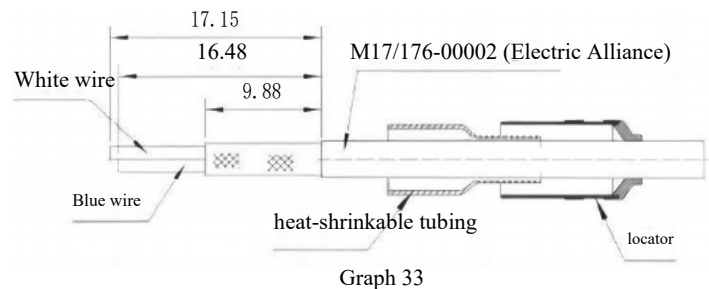

Appendix 2: Assembly Instructions for MIL-DTL-38999 Series High-Frequency Contact Components

② As shown in Figure 34, first install the shielding crimping sleeve onto the cable sheath. Then place the shielding layer over the crimping sleeve. Finally, remove the internal conductors as illustrated (cutting the filler near the shielding layer is permissible).
filling)

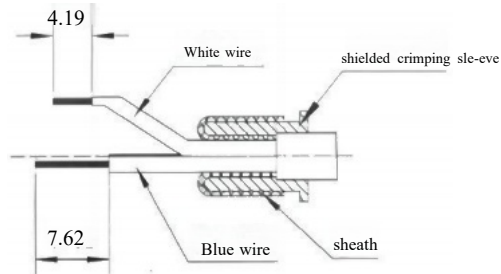

Graph 34

③ As shown in Figure 35, bend the white wire outward and insert it into the insulator's slot. The blue wire should pass through the insulator, with its tail pressing against the shielding layer.

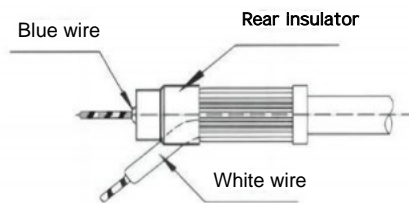

Graph 35

④ As shown in Figure 36, follow these requirements:

- Insert the inner conductor of the blue wire into the central pin contact, and the conductor must be visible through the observation hole. The contact should press against the insulator's tail, which in turn should press against the metal sleeve ring.
- Use the crimping tool M22520/2-01 and the locator K709, as shown in Table 3, to crimp the center pin contact onto the blue conductor.

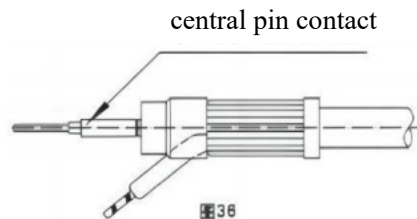

⑤ As shown in Figure 37, follow these requirements:

The middle pin contact and its inner insulator are put on the central pin contact.

- Insert the inner conductor of the white wire into the hole on the rear surface of the central contact. The conductor should be visible through the wire observation hole. The central contact must press against the insulator.
- Use the crimping tool M22520/5-01 and the crimping die Y631B shown in Table 3 to crimp the intermediate contact onto the white wire.

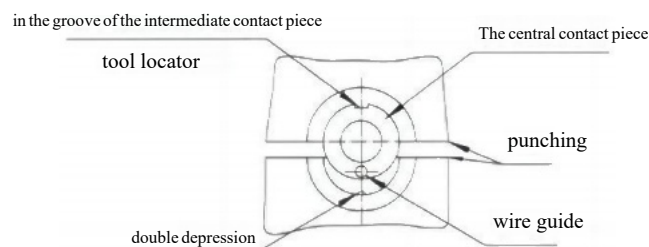
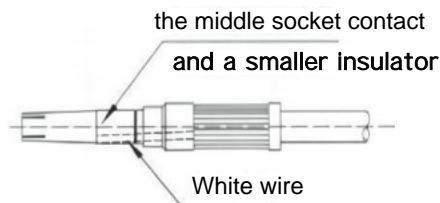

graph 37

⑥ As shown in Figure 38, pressing further requires:

- a. Fit the external pins and insulator onto the central contact assembly until fully seated.
- b. When the component is fully seated at the bottom, perform hexagonal crimping on the housing end using the crimping tool M22520/5-01 and crimping die Y631A as specified in Table 3.
- c. Slide the heat shrink sleeve to the part where the contact has been crimped, then heat both the contact and the heat shrink sleeve on the cable.

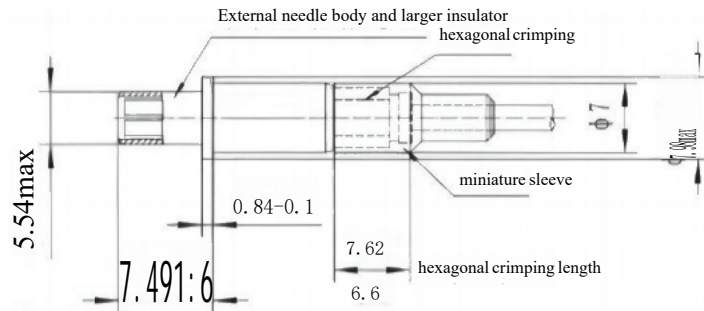

Graph 38

8 assembly of dual coaxial blind plug holes

① As shown in Figure 39, the heat-shrink sleeve and locator slide onto the cable sheath, starting from the smaller-diameter end.

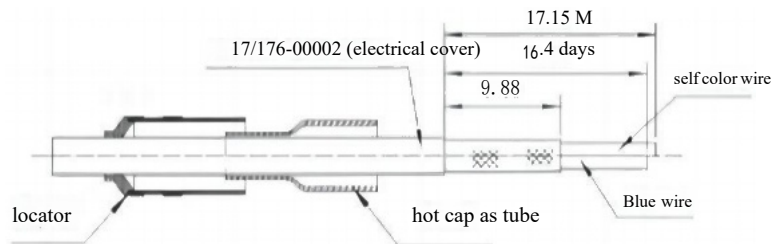

Graph 39

③ As shown in Figure 40, install the shielding crimping sleeve over the cable sheath. Then, place the shielding layer onto the crimping sleeve. Following the diagram, strip the internal conductors (cutting the filler near the shielding layer is permissible).thing) .

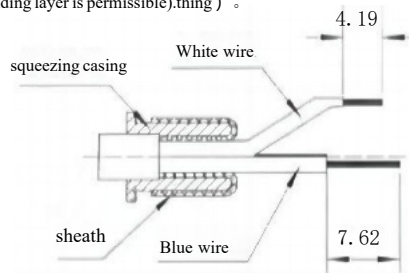

Graph 40

④ As shown in Figure 41, bend the white wire outward and insert it into the slot of the insulator. The blue wire should pass through the insulator, with its tail pressing against the shielding layer.

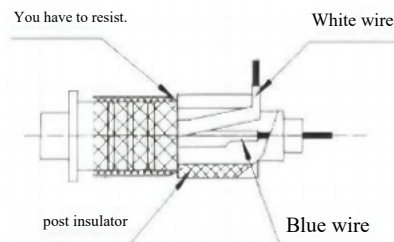

Graph 41

Appendix 2: Assembly Instructions for MIL-DTL-38999 Series High-Frequency Contact Components

⑤ As shown in Figure 42, follow these requirements:

- a. Slide the Socket Contact Onto the Blue Wire. The Conductor Must Be Visible Through the Through-Hole on the Internal Socket Contact.
- b. Use the M22520/2-01 tool and K709 locator to crimp the contact piece.

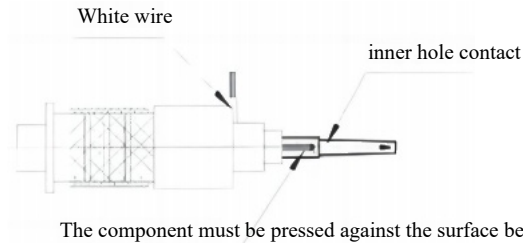

If the conductor needs to be cut
Graph 42

⑥ As shown in Figure 43, the intermediate pin contact and insulator assembly are mounted over the inner hole contact. The conductor must be visible through the observation hole on the contact. The intermediate contact must press against the tail end of the insulator.

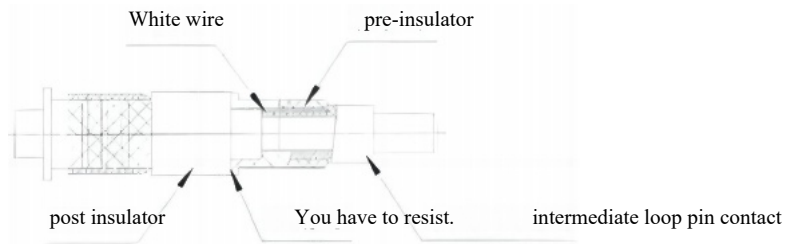

Graph 43

⑦ As shown in Figure 44, press the intermediate pin contact using the M22520/5-01 tool, and press the contact to the white wire using the Y631B punch die.

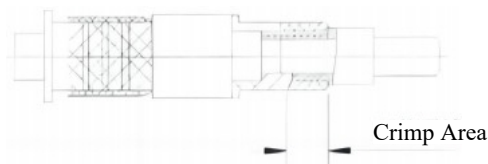

Graph 44

⑧ As shown in Figure 45, the external socket contact and the front-end insulator secondary assembly slide onto the internal assembly until they make contact. A small gap will form on the sleeve.

- a. Use the M22520/5-01 tool and Y631A punch die to press-fit external components (casing and external contacts).
- b. The preformed heat shrink sleeve is slid onto the contact piece and then shrunk by a hot air device.

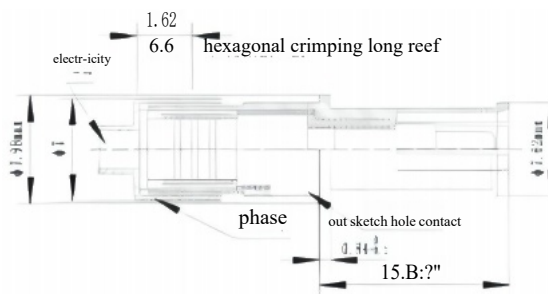

Graph 45